



# **Series I Pump**

## **Operator's Manual**

90-2517 rev A

## SAFETY SYMBOLS



EARTH GROUND



CAUTION - REFER TO MANUAL



CAUTION HIGH VOLTAGE



Scientific Systems, Inc.

349 N Science Park Rd., State College PA 16803

Phone: 800-345-5557 / 814-234-7317 Fax: 814-238-6072

[www.laballiance.com](http://www.laballiance.com)

---

# 1. INTRODUCTION

This operator's manual contains information needed to install, operate, and perform minor maintenance on the Series I Metering HPLC Pump.

## 1.1 Description of the Series I Pump

The Series I high performance metering pump is designed for routine HPLC analyses or as a dependable metering pump for general laboratory or industrial use.

The flow rate of the Series I pump can be set in 0.01 ml increments from 0.01 to 10.00 ml/min with a precision of 0.5%.

The low pulsation flow produced by the reciprocating, single-piston pump is achieved by using an advanced rapid-refill design, and programmed stepper motor acceleration.

### 1.1.1 Pump Features

The Series I Pump includes:

- Rapid refill mechanism to reduce pulsation
- PEEK™ or type 316 stainless steel pump head
- LED front panel readout of flowrate
- PRIME mode to flush out entrapped air bubbles upon start-up
- Flow adjustment in 10 microliter increments
- Microprocessor advanced control
- Digital stepper motor design to prevent flow rate drift over time and temperature
- Back panel RS232 serial communications port for complete control and status
- Remote analog inputs to control pump run/stop

### 1.1.2 Wetted Materials

Pump heads, check valve bodies, and tubing are made out of type 316 stainless steel or PEEK™, depending on version ordered. Other materials common to either stainless steel or PEEK™ models are synthetic ruby and sapphire (check valve internals and piston).

### 1.1.3 Self-Flushing Pump Head

Self-flushing pump heads provide continuous washing of the piston surface without the inconvenience of a manual flush or gravity feed arrangement. The self-flushing pump head uses a diaphragm and secondary set of check valves to create a continuous and positive flow in the area behind the high pressure pump seal. The flushing solution washes away any buffer salts that have precipitated onto the piston. If not removed, these precipitates can abrade the high pressure seal and cause premature seal failure, leakage, and can possibly damage the pump.

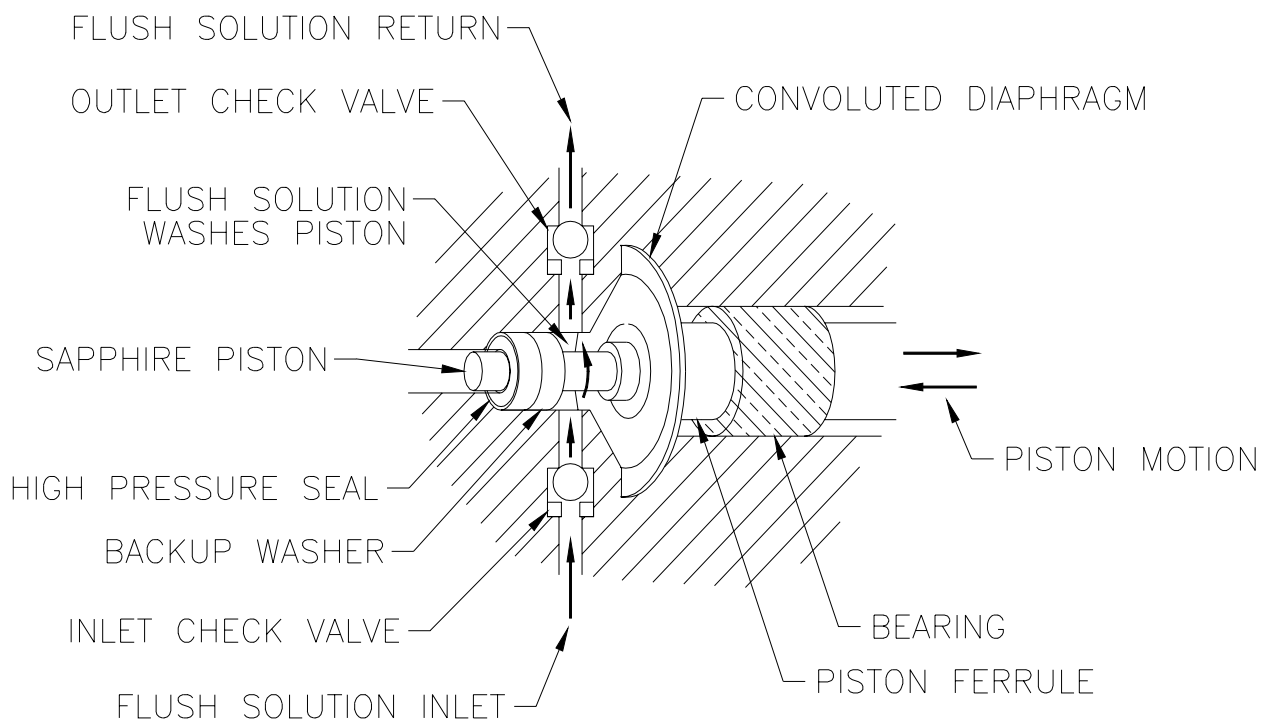

*Figure 1-1. Self-Flushing Pump Head*

## 1.2 Specifications for the Series I Pump

### **Flow Rates**                    **0.01 to 10.00 ml/min**

Pressure	0 to 2,500 psi for 10 ml Stainless Steel or Bioclean head
Flow Accuracy	3%
Flow Precision	0.5% RSD

### **Flow Rates**                    **0.1 to 40.00 ml/min**

Pressure	0 to 750 psi for 40 ml Stainless Steel or Bioclean head
Flow Accuracy	5%
Flow Precision	1.0% RSD

Dimensions	6 1/4" high, 7 3/4" wide, 14" deep
Weight	15 lb
Power	100-240 VAC, 50-60 Hz (1 Amp)
Features	Autoprime™ purging Autoflush™ piston wash
Remote Inputs	RS-232

---

## 2. INSTALLATION

### 2.1 Unpacking and Inspection

Prior to opening the shipping container, inspect it for damage or evidence of mishandling. If it has been damaged or mishandled, notify the carrier before opening the container. Once the container is opened, inspect the contents for damage. Any damage should be reported to the carrier immediately. Save the shipping container. Check the contents against the packing list.

### 2.2 Location/Environment

The preferred environment for the Series I pump is normal laboratory conditions. The area should be clean and have a stable temperature and humidity. The specific temperature and humidity conditions are 10 to 30 °C and 20% to 90% relative humidity. The instrument should be located on a stable flat surface with surrounding space for ventilation and the necessary electrical and fluid connections.

### 2.3 Electrical Connections

Unpack the Series III pump; position the pump there so that is at least a four inch clearance on all sides to permit proper ventilation. Using the power cord supplied with the pump, or equivalent, plug the pump into a properly grounded electrical outlet.

**WARNING:** Do not bypass the safety ground connection as a serious shock hazard could result.

### 2.4 Solvent Preparation

Proper solvent preparation will prevent a great number of pumping problems. The most common problem is bubble formation, which may affect the flow rate consistency. Aside from leaky fittings, the problem of bubble formation arises from two sources: solvent out-gassing and cavitation. Filtration of HPLC solvents is also required.

### *2.4.1 Solvent Out-gassing and Sparging*

Solvent out-gassing occurs because the mobile phase contains dissolved atmospheric gases, primarily N<sub>2</sub> and O<sub>2</sub>. These dissolved gases may lead to bubble formation and should be removed by degassing the mobile phase before or during use. The best practical technique for degassing is to sparge the solvent with standard laboratory grade (99.9+%) helium. Helium is only sparingly soluble in HPLC solvents, so other gases dissolved in the solvent diffuse into the helium bubbles and are swept from the system. Solvent filtration is not an effective alternative to helium degassing.

It is recommended that you sparge the solvent vigorously for 10 to 15 minutes before using it. Then maintain a trickle sparge during use to keep atmospheric gases from dissolving back into the mobile phase. The sparged solvent must be continually blanketed with helium at 2 to 3 psi. Non-blanketed, sparged solvents will allow atmospheric gases to dissolve back into the mobile phase within four hours.

Solvent mixtures using water and organic solvents (like methanol or acetonitrile) hold less dissolved gas than pure solvents. Sparging to reduce the amount of dissolved gas is therefore particularly important when utilizing solvent mixture.

Even with sparging some out-gassing may occur. A back pressure regulator installed after the detector flow cell will help prevent bubbles from forming and thus limit baseline noise.

### *2.4.2 Cavitation*

Cavitation occurs when inlet conditions restrict the flow of solvent and vapor bubbles are formed during the inlet stroke. The key to preventing cavitation is to reduce inlet restrictions. The most common causes of inlet restrictions are crimped inlet lines and plugged inlet filters. Inlet lines with tubing longer than 48" (120 cm) or with tubing of less than 0.085" (2 mm) ID may also cause cavitation.

Placing the solvent reservoirs below the pump level also promotes cavitation. The optimal location of the reservoirs is slightly above the pump level, but it is adequate to have them on the same level as the pump.

### 2.4.3 Filtration

Solvent filtration is good practice for the reliability of the Series I pump and other components in a HPLC system. Solvents should always be filtered with a 0.5 micron filter prior to use. This ensures that no particles will interfere with the reliable operation of the piston seals and check valves. Solvents in which buffers or other salts readily precipitate out will need to be filtered more often. After filtration, the solvents should be stored in a closed, particulate-free bottle.

### 2.4.4 Solvents With Harmful Effects

Except for PEEK™ pump heads, all portions of the Series I pump that contact mobile phase are manufactured of type 316 stainless steel, ceramic, sapphire, or ruby. Some of these materials are extremely sensitive to acids (including some Lewis acids) and acid halides. Avoid using solvents that contain any amount of hydrochloric acid.

Some solvents you should specifically avoid are:

Aqua Regia	Hydrochloric Acid
Bromine	Hydrofluoric Acid
Chlorine Anhydrous	Hydrofluorsilicic Acid
Copper Chloride	Hydrogen Peroxide
Ferric Chloride	Iodine
Ferrous Chloride	Mercuric Chloride
Freon 12 (wet)	
Guanidine	
Hydrobromic Acid	

In addition, some users of HPLC systems have observed that chloroform and carbon tetrachloride slowly decompose to liberate hydrochloric acid, which, as noted above, attacks stainless steel. Do not leave these solvents in the systems for a prolonged period.

You may also want to avoid ammonium hydroxide. Although ammonium hydroxide will not harm the pump itself, it is likely to damage the stator and rotor in injection valves.

## 2.5 Instrument Installation

### *2.5.1 Mobile Phase Reservoirs*

The mobile phase reservoir should be placed at the same level or slightly higher than the pump, never below the pump, and the inlet tubing should be as short as practical. These steps minimize pressure losses on the inlet side of the pump during refill and help to avoid bubble formation. These steps are particularly important when using high vapor pressure solvents (hexane, methylene chloride, etc.). Mobile phases should be degassed, filtered and covered. (See Section 2.4.)

### *2.5.2 Self-Flush Solution*

Self-flush heads require 250-500 mL of 20% methanol in water as a flushing solution. A pH indicator that will indicate the concentration of salts in the solution is recommended as a reminder to change the solution. This flush solution should be replaced with a fresh solution weekly to avoid frequent pump maintenance.

### *2.5.3 Inlet Tubing and Filters*

The spare parts list shows the inlet tubing and filter used in the Series I pumps. All inlet lines are supplied in a 30" (76 cm) length and are made of a fluoropolymer material.

### *2.5.4 Outlet Tubing*

Outlet tubing (not supplied with the pump) should have a 1/16" outer diameter. It is available in PEEK™ with a 0.020" inner diameter and is normally used before the injection valve. Tubing with a 0.010" inner diameter is normally used after the injection valve. The tubing must be cut squarely and with no burrs. The tube itself should not be crimped and the center hole must be open. PEEK™ tubing may be cut with a plastic tubing cutter or razor knife. Refer to Appendix B Page 7-7

### *2.5.5 Priming the Pump and the Flushing Lines*

Connect a syringe to the priming adapter. Run the pump at a flowrate of 3 to 5 ml/min. Prime the pump by pulling mobile phase and any air bubbles through the system and into the syringe (a minimum of 20 ml).

To prime the flush lines for a self-flush head, simply place the inlet line in the flush solution and connect a syringe to the outlet line and apply suction until the line is filled with flush solution. Place the outlet line in the flush solution. Secure both flush lines in the flush solution container so they stay immersed during pump operation.

## 2.6 Preparation for Storage or Shipping

### 2.6.1 *Isopropanol Flush*

Disconnect the outlet tubing from the pump. Place the inlet filter in isopropanol. Use a syringe to draw a minimum of 50 ml through the pump. Pump a minimum of 5 ml of isopropanol to exit. Leave the inlet tubing connected to the pump. Place the inlet filter in a small plastic bag and attach it to the tubing with a rubber band. Plug the outlet port with the shipping plug or leave a length of outlet tubing on the pump or cover the outlet port with plastic film.

### 2.6.2 *Packaging for Shipping*

**CAUTION:** Reship in the original carton, if possible. If the original carton is not available, wrap the pump in several layers of bubble wrap and cushion the bottom, top, and all four sides with 2" of packaging foam. Although heavy, an HPLC pump is a delicate instrument and must be carefully packaged to withstand the shocks and vibration of shipment.

---

## 3. OPERATION

### 3.1 Front Panel Controls and Indicators

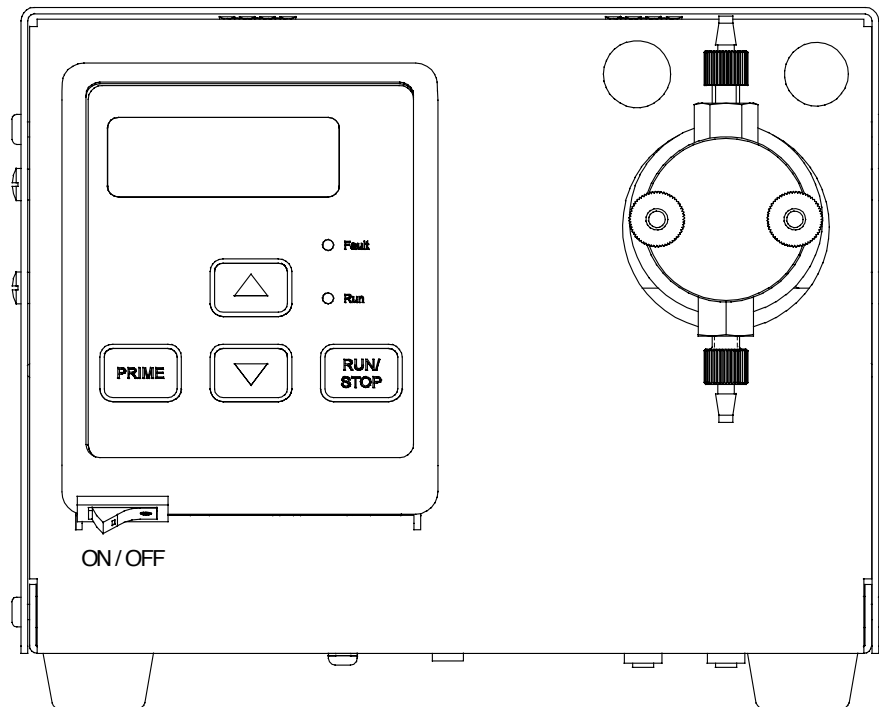

*Figure 3-1. Series I Pump Front Panel*

#### 3.1.1 Control Panel

##### 3.1.1.1 Digital Display

The 3-digit display shows the pump flow rate (ml/min) when operating.

##### 3.1.1.2 Keypad



When pressed, this button alternately starts and stops the pump.



When pressed, this button increases the flow rate.



When pressed, this button decreases the flow rate.



When the PRIME button is pressed, the pump runs at the maximum flow rate for the pump head. It will stop when any button is pressed.

**CAUTION:** When you press the PRIME key, the pump will run at the maximum flow rate. Be sure the outlet tubing is disconnected from the column and directed to a waste reservoir.

**Fast And Slow Button Repeat On The Up And Down Arrow Buttons:** If the UP-ARROW or DOWN-ARROW button is held down for more than approximately one half of a second, the button press will repeat at a slow rate of approximately 10 times a second. Once slow button repeat has begun, fast button repeat can be initiated by using a second finger to press down the second arrow button. During fast button repeat, the button press will repeat at a rate of approximately 100 times a second. Switching back and forth between repeat speeds can be accomplished by pressing and releasing the second arrow button while keeping the first arrow button held down.

### 3.1.1.3 Status LEDs

PUMP RUN      Lights to indicate that the pump is running.

FAULT            Lights when a motor stall fault occurs.

#### 3.1.1.4 Power-Up Configuration

**Non-volatile Memory Reset:** If the pump is operating erratically, there is the possibility that the memory has been corrupted. To reset the memory and restore the pump to its default parameters press and hold the UP-ARROW button when the power is switched on. Release the button when the display displays "rES". The parameters stored in non-volatile memory, the flowrate and pressure compensation, will be set to the factory default values. The head type setting is the only parameter not changed by the non-volatile memory reset function. If the firmware is upgraded to a newer version, a non-volatile memory reset will automatically occur the first time the power is switched on.

**Pressure Compensation:** On power-up, press the PRIME button on the front panel while pressing the POWER ON switch on the rear of the pump. The pump will display a number from 0 to 25. This represents the running pressure of the pump from 0 psi to 2,500 psi. Each digit represents 100 psi. To change the pressure compensation number use the up arrow and down arrow buttons. After you have selected the correct pressure compensation, press the RUN button to return to normal operation of the pump.

**Pump Head Selection:** In addition to the plastic PEEK 10 mL/min head, a stainless steel 10 mL/min head with spring loaded check valves are available. With the spring loaded check valves, reliable flowrates below 150 PSI can be attained. To switch the pump's head type, press and hold the RUN/STOP button while the power is switched on and then release the button. Use the UP-ARROW and DOWN-ARROW buttons to change between the stainless steel 10 mL/min head (S10) and plastic PEEK 10 mL/min head (P10) settings. To exit this mode, press the RUN/STOP button.

### 3.1.1.5 Power-UP Tests

**Display Software Version Mode:** The software version can be displayed during power-up by pressing and holding the RUN/STOP and the UP-ARROW buttons while the power is switched on. Release the buttons when the display displays "UEr". The decimal point number displayed on the display is the software version. To exit this mode, press the RUN/STOP button.

**Align Refill Switch Mode:** The signal that initiates the refill phase is displayed during power-up by pressing and holding the PRIME and the UP-ARROW buttons while the power is switched on. Release the buttons when the display displays "rFL". When the slotted disk allows the light beam to pass from the emitter to the detector on the slotted optical switch, a pulse will be generated which signals the beginning of refill. When this pulse occurs the three horizontal segments displayed at the top of the display will turn off and the three horizontal segments at the bottom of the display will turn on. To exit this mode, press the RUN/STOP button.

**Serial Port Loopback Test Mode:** If an external device will not communicate to the pump via the serial port, the serial port loopback test can be used to verify that the serial port is functioning properly. During power-up, press and hold the UP-ARROW and the DOWN-ARROW buttons while the power is switched on and then release the buttons. The display must display "C00" for the first half of the test to pass. Plug in the serial port loop back plug (a modular plug with pins 2 & 5 jumpered together and pins 3 & 4 jumpered together.). The display must display "C11" for the second half of the test to pass. To exit this mode, press the RUN/STOP button.

### 3.2 Rear Panel Remote Input

An RS-232C modular jack is provided on the back panel. A computer, with appropriate software, can be used as a remote controlling device for pump operation via this connection.

See Appendix A for details on connection and operation.

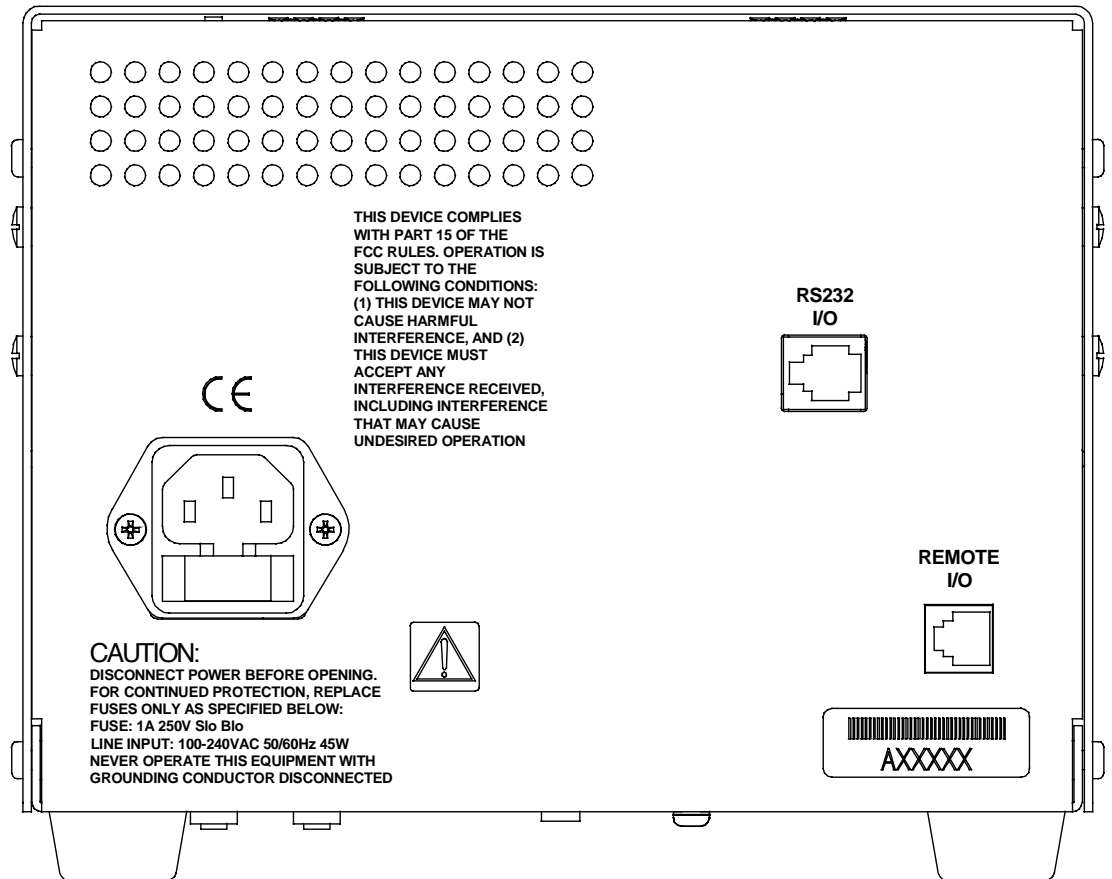

Figure 3-2. Series I Pump Rear Panel

---

## 4. THEORY OF OPERATION

### 4.1 Mechanical Operation

#### 4.1.1 *Liquid System Flow Path*

The flow path of the Series I pump starts at the inlet reservoir filter, passes through the inlet check valve, then through the pump head, and finally exits through the outlet check valve.

#### 4.1.2 *Pump Cycle*

The pump cycle consists of two phases, the pumping phase, when fluid is metered out of the pump at high pressure, and the refill phase, when fluid is rapidly drawn into the pump.

During the pumping phase, the pump piston moves forward at a programmed speed; this results in a stable flow from the pump. The piston is driven by an eccentric bearing which is directly driven by the motor.

At the end of the pumping phase, the pump enters the refill phase. The piston quickly retracts, refilling the pump head with solvent, and the piston begins to move forward again as the pumping phase begins.

The motor speed is increased during refill to reduce refill time and to pre-compress the solvent at the beginning of the pumping phase. Since the output flow completely stops during refill, an optional, external pulse damper is necessary for applications requiring extremely low pulsation levels.

For optimal operation of the check valves, a back-pressure of at least 25 psi is required. Operating at lower pressures can lead to improper seating of the valves and subsequently inaccurate flow rates.

#### 4.1.3 *Pulse Damping (optional external accessory)*

The diaphragm-type pulse damper consists of a compressible fluid (isopropanol) held in an isolated cavity by an inert but flexible diaphragm. During the pumping phase of the pump cycle, the fluid pressure of the mobile phase displaces the diaphragm, compressing the fluid in the cavity and storing energy. During the pump refill phase the pressure on the diaphragm is reduced and the compressed fluid expands, releasing the energy it has stored. This helps to stabilize flow rate and pressure. The amount of mobile phase in contact with the pulse damper is small, only 0.9 mL at 2,500 psi, and the geometry

used insures that the flow path is completely swept, so solvent “memory effects” are virtually eliminated.

To be effective, the pulse damper requires a back-pressure of approximately 500 psi or greater. If the system does not generate 500 psi, a length of small bore tubing (restrictor) can be used between the pulse damper and the application.

## **4.2 Electronic Control**

### *4.2.1 Microprocessor Control*

The pump is controlled by hybrid microprocessor circuitry which (1) provides control signals to the motor drive circuitry, (2) interfaces with the keyboard/display, (3) receives signals from the refill flag, and (4) provides external input/output (RS-232) interfacing. Firmware programming is stored in an EPROM.

An eccentric cam provides refill in a fraction of the full cam cycle. The remaining revolution of the cam provides piston displacement for outward flow of the mobile phase. In addition to the rapid refill characteristics of the drive, the onset of refill is detected by an infrared optical sensor. The microprocessor changes the refill speed of the motor to an optimum for the set flow rate. At 1ml/min, the refill rate is more than five times faster than if the motor operated at constant speed. The optimum refill rate minimizes the resulting pulsation while avoiding cavitation in the pump head.

The flow rate of any high pressure pump can vary depending on the operating pressure and the compressibility of the fluid being pumped. The Series I pump is calibrated at 1000 psi using a 80:20 mixture of water and isopropanol.

### *4.2.2 DC Power Supply*

Power for the pump is provided by Universal power supply which accommodates voltages of 110 to 240 VAC.

### **4.2.3 Remote Interfacing**

An RS-232C modular jack is provided on the back panel. See Section 3.2 for information on pump operation via this connection.

### *4.2.3 Motor Stall Detector*

The motor can stall and create a loud buzzing sound if the flow path connected to the pump's outlet becomes plugged, if the pressure exceeds the maximum pressure rating of the pump, or if the

mechanism jams. If a motor stall occurs, the electrical current being supplied to the motor is turned off and the fault light is turned on.

The Motor Stall Detector is enabled or disabled during power-up by pressing and holding the RUN/STOP and the PRIME buttons while the power is switched on. Release the buttons when the display displays "SFE". To enable the Motor Stall Detector press the UP-ARROW button and the display will display "On". To disable the Motor Stall Detector press the DOWN-ARROW button and the display will display "OFF". To exit this mode and store the current setting in non-volatile memory, press the RUN/STOP button.

The Motor Stall Detector uses a timer to determine if the camshaft has stopped turning or if the refill switch is defective. The timer begins timing after the pump accelerates or decelerates to its set point flow rate. If the Motor Stall Detector has been enabled, and the camshaft stops turning or the refill switch stops operating, the fault will be detected between the time it takes to complete 1 to 2 pump cycles. A pump cycle is defined as the time it takes for the camshaft to complete one complete revolution. One revolution of the camshaft produces a delivery phase and a refill phase. Each specific flow rate has a corresponding cycle time. For a pump with an analytical (standard) 10 mL/min pump head, the cycle time is approximately: 30 seconds at 0.1 mL/min, 3 seconds at 1.00 mL/min, and 0.3 seconds at 10.00 mL/min.

The fault is canceled by using one of the following methods: (1) by pressing the RUN/STOP button on the front panel, (2) by sending a stop command "ST" via the serial communications port on the back panel, or (3) by connecting the PUMP-STOP input to COM on the back panel, or removing the connection between the PUMP-RUN input and COM if the PUMP-STOP input is permanently jumpered to COM on the back panel. Note: the PUMP-RUN, PUMP-STOP, and COM are an option and do not exist on the standard pump.

#### *4.2.4 Remote Interfacing*

An RS-232C modular jack is provided on the back panel. A computer, with appropriate software, can be used as a remote controlling device for pump operation via this connection.

---

## 5. MAINTENANCE

Cleaning and minor repairs of the Series I pump can be performed as outlined below.

Lower than normal pressure, pressure variations, or leaks in the pumping system can all indicate possible problems with the piston seal, piston, or check valves. Piston seal replacement could be necessary after 1000 hours of running time.

### 5.1 Filter Replacement

#### 5.1.1 Inlet Filters

Inlet filters should be checked periodically to ensure that they are clean and not restricting flow. A restriction could cause cavitation and flow loss in the pump. Two problems that can plug an inlet filter are microbial growth and impure solvents. To prevent microbial growth, use at least 10-20% organic solvent in the mobile phase or add a growth-inhibiting compound. If you pump 100% water or an aqueous solution without any inhibitors, microbes will grow in the inlet filter over time, even if you make fresh solution every day. Always use well filtered, HPLC grade solvents for your mobile phase.

### 5.2 Pump Heads

#### 5.2.1 Removing the Pump Head

As a guide to pump head assembly, the standard pump head is shown in Figure 5-1 and figure 5-2.

1. Turn OFF the power to the Series I pump.
2. Remove the inlet line and filter from the mobile phase reservoir. Be careful not to damage the inlet filter or crimp the Teflon tubing.
3. Optionally remove the outlet line from the outlet check valve.
4. Momentarily turn ON the Series I pump and quickly turn OFF the power upon hearing the refill stroke. This reduces the extension of the piston and decreases the possibility of piston breakage.
5. Unplug the power cord.

- Carefully remove the two knurled nuts at the front of the pump head.

**CAUTION:** Be careful not to break the piston when removing the pump head. Twisting the pump head can cause the piston to break.

- Carefully separate the pump head from the pump. Move the pump head straight out from the pump and remove it from the piston. Be careful not to break or damage the piston. Also remove the seal and seal backup washer from the piston if they did not stay in the pump head. Remove the O-ring.
- Carefully separate the flush housing from the pump. Move the flush housing straight out from the pump and remove it from the piston. Be careful not to break or damage the piston. Also remove the self-flush diaphragm from the piston by carefully grasping the sealing flange on two sides and sliding it straight out on the piston being careful not to exert side pressure that may break the piston.

### *5.2.2 Replacing Piston Seals*

Lower than normal pressure, pressure variations, and leaks in the pumping system can all indicate possible problems with the piston seal. Depending on the fluid or mobile phase used, piston seal replacement is often necessary after 1000 hours of running time.

The spare parts table details the pump head types and appropriate seal kit choices. Each replacement seal kit contains one seal, one backup washer, a seal insertion/removal tool, a diaphragm and a pad to clean the piston when changing the seal.

#### **5.2.2.1 Conditioning New Seals**

Note: Use only organic solvents to break-in new seals. Buffer solutions and salt solutions should never be used to break-in new seals.

Using a restrictor coil or a suitable column, run the pump with a 50:50 solution of isopropanol (or methanol) and water for 30 minutes at the back pressure and flow rate listed under PHASE 1 below and according to the pump head type.

#### **PHASE 1**

<b>Pump Head Type</b>	<b>Pressure</b>	<b>Flow Rate</b>
10 ml Bioclean	2000 psi	<3 ml/min.

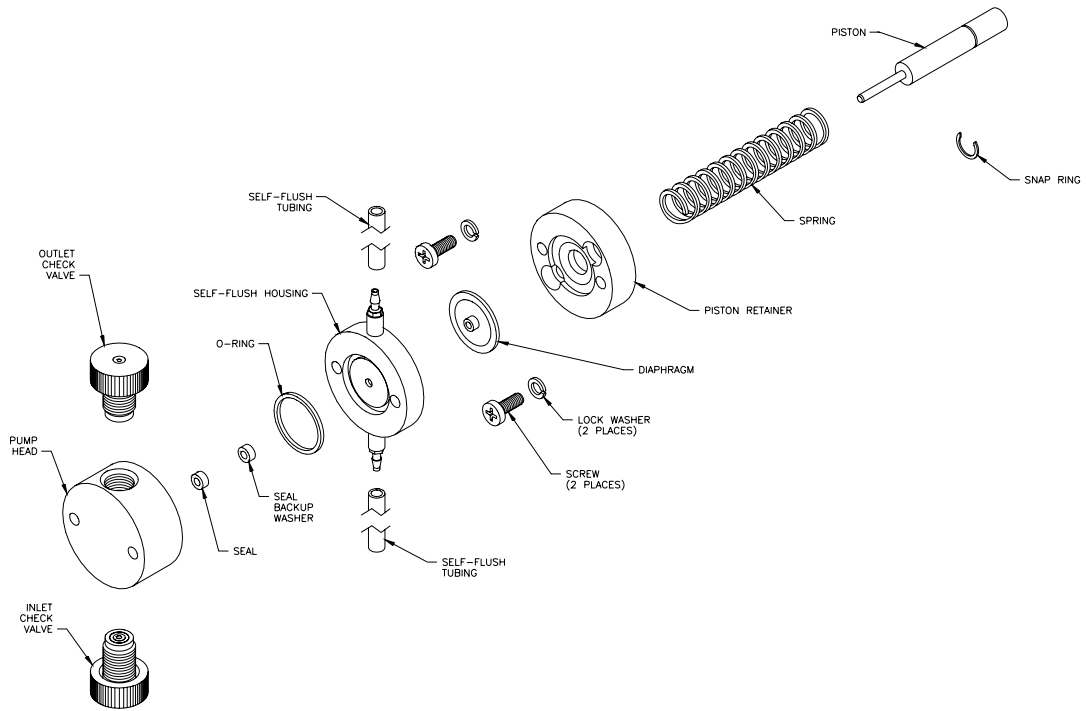
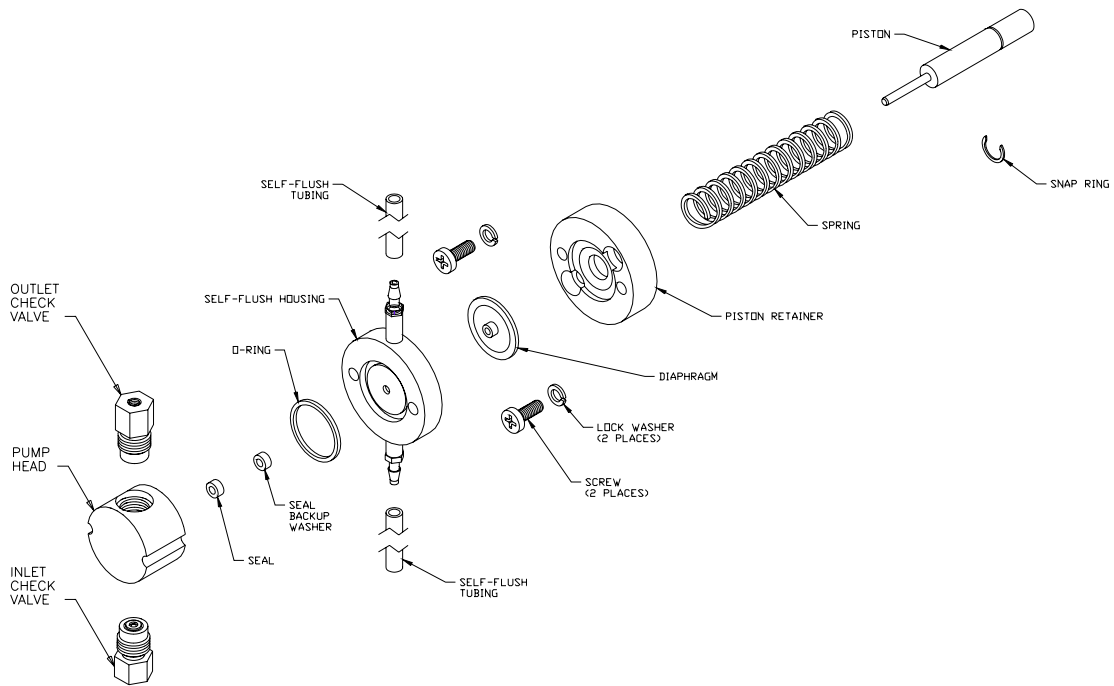

Figure 5-1. Bioclean Self-Flushing Pump Head Assembly



*Figure 5-2. Stainless Steel Self-Flushing Pump Head Assembly*

### 5.2.3 Cleaning the Pump Head Assembly

Note: If you choose to remove the piston seal or self-flush diaphragm, you should have a new set on hand to install after cleaning. It is not recommended that you reinstall the used piston seal or diaphragm since they are likely to be scratched and damaged during removal and would not provide a reliable seal if reused. If you decide to remove the seal, use only the flanged end of the plastic seal removal tool supplied with the seal replacement kit, and avoid scratching the sealing surface in the pump head. See Section 5.2.2 for seal replacement instructions.

1. Inspect the piston seal cavity in the pump head. Remove any foreign material using a cotton swab or equivalent, and avoid scratching the sealing surfaces. Be sure no fibers from the cleaning swab remain in the components.
2. The pump head, check valves, and flushing housing may be further cleaned using a laboratory grade detergent solution in an ultrasonic bath for at least 30 minutes, followed by rinsing for at least 10 minutes in distilled water. Be sure that all particles loosened by the above procedures have been removed from the components before reassembly.
3. If the check valves had been removed, tighten each check valve firmly by hand. Each check valve assembly contains two capsules. The sapphire seat in each capsule must be oriented downward in all cases in the final pump assembly.

Note: The inlet check valve has a larger opening (1/4"-28, flat-bottom seat) for the 1/8" inlet tubing; the outlet check valve has a smaller opening (#10-32, cone seat) for the 1/16" outlet tubing. The inlet check valve must be connected at the larger opening in the pump head if present.

If the piston seal has been removed, insert a new seal as described in Section 5.2.2, then continue with Section 5.2.5 to replace the pump head.

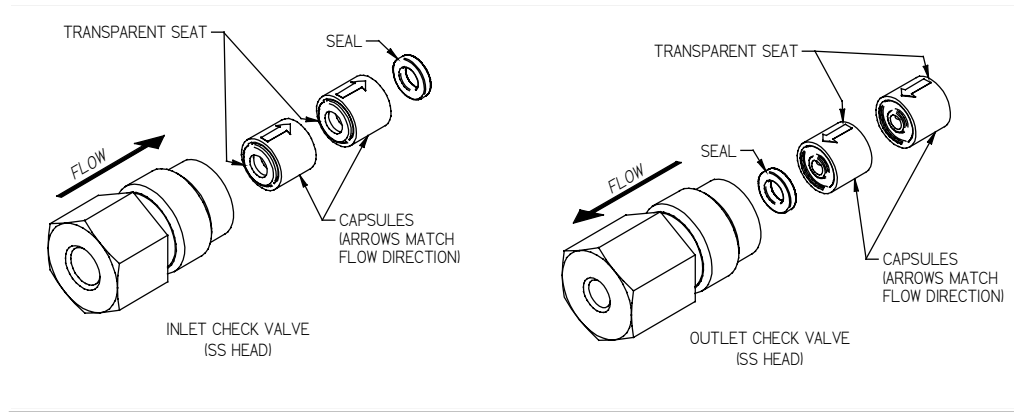

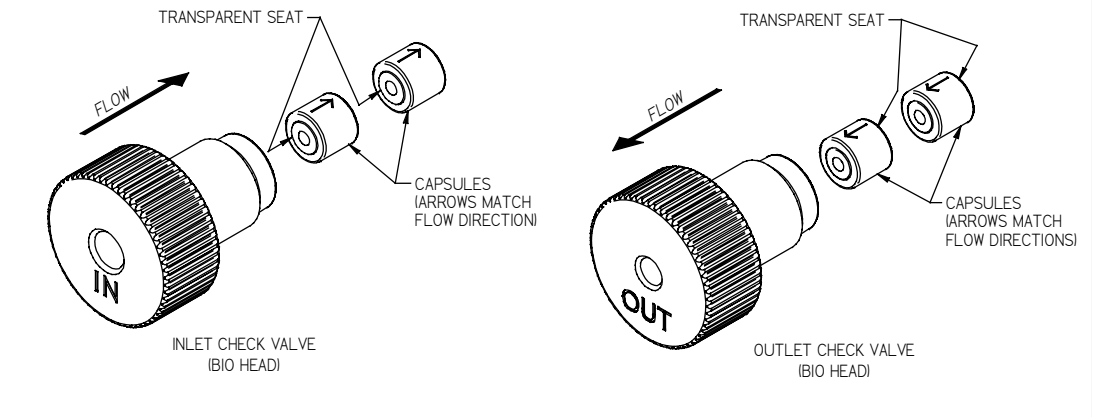

*Figure 6. Check Valves*

#### 5.2.3.1 Removing the Seals

1. Remove the pump head as described in Section 5.2.1.
2. Insert the flanged end of the seal insertion/removal tool into the seal cavity on the pump head. Tilt it slightly so that flange is under the seal and pull out the seal.

**CAUTION:** Using any other “tool” will scratch the finish.

3. Inspect, and if necessary, clean the pump head as described in Section 5.2.3.

### **5.2.3.2 Cleaning the Piston**

1. It is not necessary to remove the piston from the housing to clean the piston. Use the scouring pad included in the seal replacement kit to clean the piston. Gently squeeze the piston within a folded section of the pad and rub the pad along the length of the piston. Rotate the pad frequently to assure the entire surface is scrubbed. Do not exert pressure perpendicular to the length of the piston, as this may cause the piston to break. After scouring, use a lint-free cloth, dampened with alcohol, to wipe the piston clean.

### **5.2.3.3 Replacing the Seal**

1. Place a high pressure replacement seal on the rod-shaped end of the seal insertion/removal tool so that the spring is visible when the seal is fully seated on the tool. Insert the tool into the pump head so that the open side of the seal enters first, facing the high pressure cavity of the pump head. Be careful to line up the seal with the cavity while inserting. Then withdraw the tool, leaving the seal in the pump head. When you look into the pump head cavity, only the polymer portion of the seal should be visible.
2. Attach the pump head as described in Section 5.2.5.
3. Condition the new seal as described in Section 5.3.

### **5.2.4 Changing the Piston**

1. Remove the pump head as described in Section 5.2.1.
2. With your thumb pressing the piston retainer against the pump housing, remove the two philips head screws from the retainer. Do not allow the spring pressure to force the retainer away from the housing as the screws are loosened.
3. After both screws have been removed, slowly allow the spring pressure to push the retainer out of the housing. Gently pull the retainer straight out and carefully remove it from the piston and threaded rods. Also, gently pull the spring straight out of the housing and remove.
4. Grasp the metal base of the piston assembly so that you avoid exerting any pressure perpendicular to the length of the piston, and gently pull it from the pump housing.

5. Remove the snap ring from the groove on the old piston and place it into the groove on the new piston.
6. Place a small amount of high quality grease on the back end of the metal base of the piston assembly. Grasp the metal base of the piston assembly near the front so that you avoid exerting any pressure perpendicular to the length of the piston, and gently slide it into the pump housing.
7. Gently slide the spring over the piston assembly and back into the pump housing. Carefully align the retainer and gently push it straight in against the spring force until the retainer is against the housing. If misalignment with the piston occurs, wiggle while pushing the retainer to align the piston & retainer.
8. Hold the retainer flush against the housing with your thumb. Insert and tighten the philips head screws. Do not allow the spring pressure to force the retainer away from the housing. Insure that there are no gaps between the retainer and the housing.
9. Attach the pump head as described in Section 5.2.5.

#### *5.2.5 Replacing the Pump Head*

1. Gently place diaphragm onto piston with center hub protruding towards you. Push diaphragm all the way back into recess and against metal base of piston. Do not exert pressure perpendicular to the length of the piston, as this may cause the piston to break.
2. Carefully align the flush housing and gently slide it into place on the pump. Make sure that the Inlet valve is on the bottom and the Outlet valve is on the top. Install the o-ring in its grove.
3. Line up the pump head and carefully slide it into place. Be sure that the Inlet valve is on the bottom and the Outlet valve is on the top. Do not force the pump head into place.
4. Finger tighten both knurled nuts into place. To tighten firmly, alternately turn nuts 1/4 turn while gently wiggling the pump head to center it.
5. Reattach the inlet and outlet lines. Change the flushing solution.

### 5.3 Check Valve Cleaning and Replacement

Many check valve problems are the result of small particles interfering with the operation of the check valve. As a result, most problems can be solved by pumping a strong solution of liquid laboratory grade detergent through the check valves at a rate of 1 ml/min for one hour. After washing with detergent, pump distilled water through the pump for fifteen minutes. Always direct the output directly to a waste beaker during cleaning. If this does not work, the check valve should be replaced.

### 5.4 Lubrication

The Series I pump has no lubrication requirements. The bearings in the pump housing and piston carrier are permanently lubricated and require no maintenance. Keeping the interior of the pump free of dirt and dust will extend the pump's useful life.

### 5.5 Fuse Replacement

Three fuses protect the Series I pump. Two of the fuses are located in the power entry module at the rear of the cabinet and are in series with the AC input line. The other fuse is located on the circuit board and is in series with the 24 Vdc supply.

Troubleshooting the fuses is straightforward. If the power cord is plugged in and the on/off power entry switch is on and the display does not light, check the two fuses in the power entry module. To gain access to these fuses, gently pry off the cover plate with a small flat-bladed screwdriver. Replace with fuses of the correct rating: 1 A slow-blo fuse.

If the front panel appears to function normally but the pump motor does not run, check the fuse located on the circuit board. Replace it with a 5 A fast-blo fuse.

**WARNING:** Unplug power cord before removing cabinet lid.

## Quick Guide to Problem Solving

You Notice	This May Mean	Possible Cause	You Should
<ol style="list-style-type: none"> <li>1. Uneven pressure trace.</li> <li>2. Pressure drops.</li> <li>3. No flow out the outlet check valve.</li> </ol>	<ol style="list-style-type: none"> <li>1. Bubble in check valve.</li> <li>2. Leaks in system.</li> <li>3. Dirty check valve.</li> <li>4. Bad check valve.</li> </ol>	<ol style="list-style-type: none"> <li>1. Solvent not properly degassed.</li> <li>2. Fittings are not tight.</li> <li>3. Mobile phase not properly filtered.</li> <li>4. Particles from worn piston seal caught in check valve.</li> <li>5. Plugged inlet filter.</li> </ol>	<ol style="list-style-type: none"> <li>1. Check to be certain that mobile phase is properly degassed.</li> <li>2. Check connections for leaks by tightening fittings.</li> <li>3. Prime the system directly from the outlet check valve.</li> <li>4. Clean or replace the check valves. See Section 5.4.</li> <li>5. Clean or replace inlet filter. See Section 5.1.1.</li> </ol>
<ol style="list-style-type: none"> <li>1. Uneven pressure trace.</li> <li>2. Pressure drops.</li> <li>3. Fluid between the pump head and the retainer.</li> </ol>	<ol style="list-style-type: none"> <li>1. Leaks in system.</li> <li>2. The piston seal or diaphragm is worn.</li> </ol>	<ol style="list-style-type: none"> <li>1. Fittings not tight.</li> <li>2. Long usage time since last seal / diaphragm change.</li> <li>3. Salt deposits on seal or diaphragm (especially if buffered aqueous mobile phases are used).</li> </ol>	<ol style="list-style-type: none"> <li>1. Check all connections for leaks.</li> <li>2. Replace piston seal &amp; diaphragm. See Sections 5.2 and 5.3.</li> <li>3. Check the piston for salt deposits. Clean as necessary. See Section 5.2.4.</li> </ol>
Pump makes a loud clanging or slapping noise (intermittent contact with cam).	Piston carrier is catching in piston guide.	<ol style="list-style-type: none"> <li>1. Cap nut screws on the pump head are loose.</li> <li>2. Seal(s) are worn.</li> <li>3. Piston guide is worn</li> </ol>	<ol style="list-style-type: none"> <li>1. Check cap nut screws on pump head. Tighten if necessary.</li> <li>2. Replace seals.</li> <li>3. Replace piston guide and seals. See Sections 5.2 and 5.3.</li> </ol>
No power when pump turned ON.	Blown fuses in the power entry module.	<ol style="list-style-type: none"> <li>1. Power surge.</li> <li>2. Internal short.</li> </ol>	<ol style="list-style-type: none"> <li>1. Replace only with the appropriate fuses (1A for 100/110 Vac or 1/2A for 220/240 Vac).</li> <li>2. Contact service technician if problem persists.</li> </ol>
Front panel appears OK but pump motor does not run.	Blown fuse on the circuit board.	<ol style="list-style-type: none"> <li>1. Power surge.</li> <li>2. Internal short.</li> </ol>	<ol style="list-style-type: none"> <li>1. Replace only with the appropriate fuse .</li> <li>2. Contact service technician if problem persists.</li> </ol>
PEEK fittings or components leak.	You cannot force PEEK parts with interferences to seal by brute force tightening.	<ol style="list-style-type: none"> <li>1. Film of fluid between surfaces.</li> <li>2. Salt crystals between surfaces.</li> <li>3. Scratches in mating surfaces.</li> </ol>	<ol style="list-style-type: none"> <li>1. Clean and dry mating surfaces.</li> <li>2. If scratched, replace defective part.</li> </ol>
Self-flush heads leak flush solution.	Flush area not sealed.	<ol style="list-style-type: none"> <li>1. Large (Size O16) O-ring is flattened and no longer seals.</li> <li>2. Head not sufficiently tightened.</li> <li>3. Scratches in mating surfaces.</li> <li>4. Leaky self-flush seal.</li> </ol>	<ol style="list-style-type: none"> <li>1. Replace O-ring.</li> <li>2. Tighten head.</li> <li>3. Replace leaky parts.</li> </ol>

---

## 7. LIST OF REPLACEMENT PARTS

### SERIES I, PEEK, 10ML

P/N 110PFN01

880197	Seal Kit, Aqueous, 10mL
880198	Seal Kit, Organic, 10mL
880402	Check Valve Kit
880721	Repl. Inlet Filter Elements (2)
880301	Head & S/F Kit, 10mL
880411	S/F Assembly, 10mL
880351	Series I Piston, 10mL
880501	Series I Drive Assembly, 10mL
880101	Series I PC Board Assembly
880122	Front Panel Assembly
880905	Series I-II Overlay

### SERIES I, PEEK, 40ML

P/N 140PFN01

880199	Seal Kit, Aqueous, 40mL
880200	Seal Kit, Organic, 40mL
880402	Check Valve Kit
880721	Repl. Inlet Filter Elements (2)
880303	Head & S/F Kit, 40mL
880413	S/F Assembly, 40mL
880352	Series I Piston, 40mL
880502	Series I Drive Assembly, 40mL
880101	Series I PC Board Assembly
880122	Front Panel Assembly
880905	Series I-II Overlay

## **SERIES I, SS, 10ML**

P/N 110SFN01

880197 Seal Kit, Aqueous, 10mL  
880198 Seal Kit, Organic, 10mL  
880404 Check Valve Kit  
880721 Repl. Inlet Filter Elements (2)

880302 Head & S/F Kit, 10mL  
880411 S/F Assembly, 10mL  
880351 Series I Piston, 10mL  
880501 Series I Drive Assembly, 10mL  
880101 Series I PC Board Assembly  
880122 Front Panel Assembly  
880905 Series I-II Overlay

## **SERIES I, SS, 40ML**

P/N 140SFN01

880199 Seal Kit, Aqueous, 40mL  
880200 Seal Kit, Organic, 40mL  
880404 Check Valve Kit  
880721 Repl. Inlet Filter Elements (2)

880304 Head & S/F Kit, 40mL  
880413 S/F Assembly, 40mL  
880352 Series I Piston, 40mL  
880502 Series I Drive Assembly, 40mL  
880101 Series I PC Board Assembly  
880122 Front Panel Assembly  
880905 Series I-II Overlay

---

# APPENDIX A

## A.1 Rear Panel Remote Input

An RS-232C modular jack is provided on the back panel. A computer, with appropriate software, can be used as a remote controlling device for pump operation via this connection.

See Appendix A for details on connection and operation.

### A.1.1 Hardware Implementation

The RS-232 I/O serial communications port is configured for 9600 baud, 8 data bits, 1 stop bit, and no parity. The connector is a standard RJ-11 modular telephone type jack. The pinout is:

<u>Pin</u>	<u>Function</u>
1, 6	Ground
2	DSR (Input)
3	RXD (Input to Series I pump)
4	TXD (Output from pump)
5	DTR (Output)

Special wiring considerations: Use the following chart for interfacing the Series I pump serial communications port to either a 25-pin or 9-pin serial COM port on the computer.

<u>Pump (RJ11)</u>	<u>Signal</u>	<u>IBM (DB25)<sup>a</sup></u>	<u>IBM (DB9)<sup>b</sup></u>
1, 6	Ground	7	5
2	DSR	20	4
3	RXD	2	3
4	TXD	3	2
5	DTR	6	6

<sup>a</sup> Jumper pins 4, 5, and 8 on DB25.  
<sup>b</sup> Jumper pins 1, 7, and 8 on DB9.

Cable	Part Number
Modular Cable	12-0677
Adapter RJ-11 to DB9	12-0672
Adapter RJ-11 to DB-25	12-0671

### A.1.2 Hand-Shaking

The Series I pump uses hardware handshaking. The pump will not transmit on the TXD output if the DSR input is at a low logic level. And, the pump will not receive on the RXD input when the DTR output is at a low logic level. A low logic level is -3.0 to -15 volts and a high logic level is 3.0 to 15 volts.

### A.1.3 Command Interpreter

The Series I pump's high level command interpreter receives and responds to command packets. The pump will not send a message except when prompted, and it will send a response to every message as described below.

Each command is characterized by a unique two-letter command code, and only one command can be issued per line. Case is not important; that is, the command codes "CC" "Cc" "cC" and "cc" are all equivalent. Command strings sent by the pump are terminated by the "/" character. The command packets are as follows:

Command	Response	Comments
RU	OK/	Sets the pump to the RUN state.
ST	OK/	Sets the pump to the STOP state.
FLxxx	OK/	Sets the flowrate to x.xx or xx.x mL/min where the range is fixed for the pump head size, i.e., for 0.01 to 9.99 mL/min xxx = 001 to 999.
FOxxxx	OK/	Sets the flowrate to xx.xx mL/min, i.e., for 0.01 to 10.00 mL/min xxxx = 0001 to 1000.
CC	OK,0,x.xx/ (x.xx or xx.xx)	Reads the pump flowrate in mL/min. The format is x.xx for all flowrates except 10.0 mL/min which is xx.xx.
CS	OK,x.xx,0,0,PSI,0,y,1/ (x.xx or xx.xx)	Reads the current pump setup, where: x.xx or xx.xx = Flowrate in mL/min y = Run status (0 = stopped, 1 = running)
ID	OK,vx.xx SR1X firmware/	Identifies the pump type and EPROM revision x.xx

SF	OK/	Puts the pump in fault mode. Turns on the FAULT LED and stops the pump immediately.
RF	OK,x/	Reads the motor stall fault status, where: x = 0 if no fault x = 1 during a fault condition
KD	OK/	Disables the keypad. (Default status at power-up is enabled.)
KE	OK/	Enables the keypad.
PCxx	OK/	Sets the pressure compensation value, where xx = the operating pressure (in PSI divided by 100), i.e., for 0 PSI xx = 00, for 2500 PSI xx = 25.
RC	OK,x/ (x or xx)	Reads the pressure compensation value in hundreds of PSI, i.e., for 0 PSI x = 0, for 2500 PSI xx = 25.
HTx	OK/	Sets the pump head type, where: x = 1 for a stainless steel 10 mL/min pump head x = 2 for a plastic 10 mL/min pump head The pump is stopped; and, the pressure compensation is initialized, when the head type is changed.
RH	OK,x/	Reads the pump head type, where: x = 1 for a stainless steel 10 mL/min pump head x = 2 for a plastic 10 mL/min pump head
PI	OK,a.aa,b,c,d,1,0,0,0,0,0,e, f,g,h,0,i,j,1/  (a.aa or aa.aa) (c or cc)	Reads the current pump setup, where: a.aa, aa.aa = Flowrate in mL/min b = Run status (0 = stopped, 1 = running) c or cc = Pressure compensation d = Pump head type (1 = steel, 2 = plastic) e = Priming (0 = no, 1 = yes) f = Keypad lockout (0 = no, 1 = yes) g = Pump run input (0 = inactive, 1 = active) h = Pump stop input (0 = inactive, 1 = active) i = Control mode (0 = LOCAL, 1 = REMOTE) j = Motor stall fault (0 = no, 1 = yes)
RE	OK/	Resets the pump configuration to its default power-up state.
#	(no response)	Clears all characters from the command buffer.

**A.2 RUN/STOP** A brown, modular, 6 position, female connector (marked REMOTE I/O) on the rear of the cabinet allows access to the PUMP-RUN, PUMP-STOP and COM functions. The pump will RUN when the PUMP-RUN is connected (pulsed) to the COM (low) connection. The pump will STOP when the PUMP-STOP is connected (pulsed) to the COM (low) connection. The connection positions on the receptacle are #1 - COM, #3 - STOP IN, #4 - RUN IN. The other connections are not implemented in this unit and, to avoid malfunctions, wires in these positions should be insulated from all other conductors. If a modular cable is not supplied with the unit, one can be constructed from this description and the following diagram.

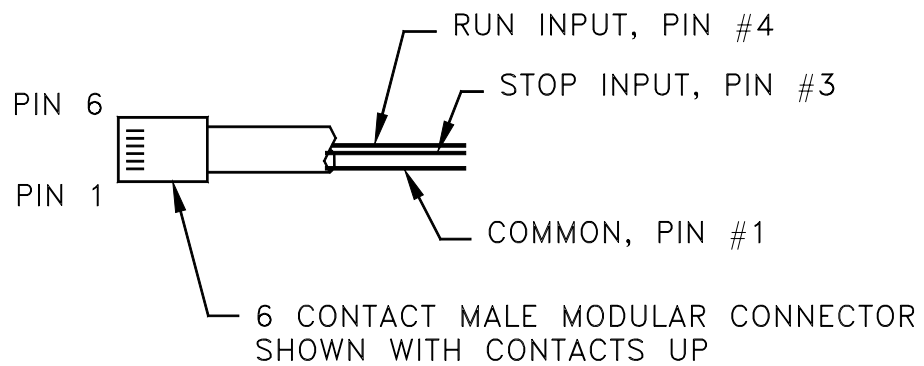

# APPENDIX B

## EZ Grip fitting Guide

1

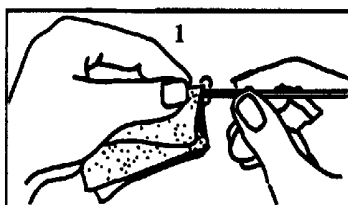

Rough the tubing surface where the ferrule will grip with a circular motion. (Sandpaper is included in the kit.) **DO NOT PULL THE SANDPAPER ALONG THE AXIS OF THE TUBE AS THIS MAY REDUCE THE HOLDING STRENGTH OF THE FERRULE.** Stainless Steel tubing has a very smooth finish and the ferrule will not hold properly unless the surface is rough. This will also help with PEEK tubing.

2

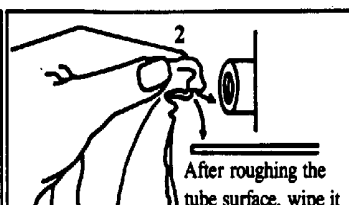

After roughing the tube surface, wipe it with a lab cloth that has been wetted with isopropanol or methanol. **DO NOT USE WATER.** Also swab out the seat in which the ferrule will sit. If there are any particles or moisture between the ferrule and the surfaces of the seat, the fitting will not seal properly. The low vapor points of methanol or isopropanol make them ideal for cleaning these surfaces.

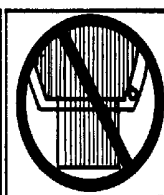

No Salt Crystals or Particles in the Seat



No Moisture in the Seat

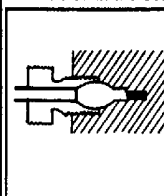

Properly Seated

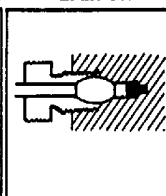

Tubing Not Fully Seated

3

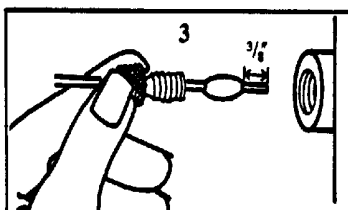

Place the gland nut and then the ferrule on the tubing. The ferrule should be placed about  $\frac{3}{8}$ " from the end of the tubing to insure that the tubing length can be fully inserted into the seat. Insert the tube fully so the tubing bottoms against the seat.

4

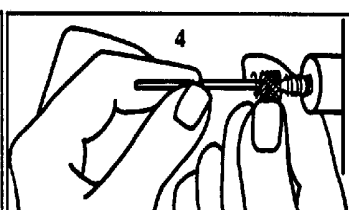

Maintain firm pressure on tubing and slide the gland nut and ferrule into the seat. Tighten the gland nut as tightly as you can with your fingers. **DO NOT USE TOOLS TO TIGHTEN THE GLAND NUT.**

5

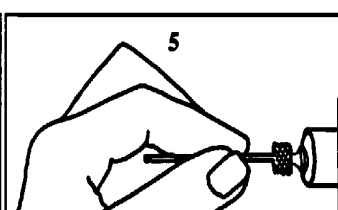

The EZ-Grip™ Gland Nut and EZ-Grip™ Ferrule should now be securely seated in the fitting. Tug on the tubing to double check the fitting.

## Warranty (Pumps and Column Ovens)

The product described in this manual, other than seals, check valves, inlet/outlet filters, pistons, and pulse damper, is warranted against defective material and workmanship for a period of three (3) years from the date of shipment. Seals and valves, whether sold independently or as component parts of other products, are warranted against defective material and workmanship for a period of ninety (90) days from date of shipment. In the event of such a defect, SSI will repair or replace the product or necessary parts therein, at its discretion, and such repair or replacement shall be the sole remedy of this warranty. This warranty is subject to the following conditions:

1. Any servicing of the products must be performed by trained personnel.
2. The products must not be subjected to abuse or improper installation or application.
3. Warranty does not extend past thirty (30) days for transducer calibration, voltage calibration, and similar features that may be part of the product.
4. This warranty shall be void as to any products exposed to:
  - (i) highly corrosive chemicals including, but not limited to halide acids, halide salts, concentrated organic or inorganic acids and their salts, any concentrated chemical that will complex metal ions, and carbon tetrachloride which can contain significant amounts of hydrochloric acid; Tetrahydrofuran and high concentrations of chlorinated solvents (PEEK components);
  - (ii) foreign materials in the driving media or pumped media;
  - (iii) application of pressures beyond published ratings.

THERE ARE NO WARRANTIES, EXPRESS OR IMPLIED, WHICH EXTEND BEYOND THIS DESCRIPTION. SSI neither assumes, nor authorizes any person to assume for it, any other liability in connection with the sale and use of the products.

DAMAGES ARE LIMITED STRICTLY TO REPLACEMENT OF THE PRODUCTS. SSI EXPRESSLY DISCLAIMS LIABILITY FOR INCIDENTAL AND CONSEQUENTIAL DAMAGES RESULTING FROM THE USE OF THE PRODUCTS.

Claims covered by this warranty will be honored when presented within 30 days from discovery of defect.