

Prep 36 Pump

Dual Piston Pump



Operator's Manual

90-2707 rev E

SAFETY SYMBOLS



EARTH GROUND



CAUTION - REFER TO MANUAL



CAUTION HIGH VOLTAGE



Scientific Systems, Inc.

349 N Science Park Rd., State College PA 16803

Phone: 800-441-4752 / 814-234-7317 Fax: 814-238-7532

www.laballiance.com

Table of Contents

1. INTRODUCTION	1
1.1 Description of the Prep Pump	1
1.1.1 Pump Features.....	1
1.1.2 Wetted Materials	2
1.1.3 Self-Flushing Pump Heads	2
1.1.4 Self-Flush and Seal Life	3
1.2 Specifications for the Prep 36 Pump	4

2. INSTALLATION	1
2.1 Unpacking and Inspection	1
2.2 Location/Environment	1
2.3 Electrical Connections	1
2.4 Solvent Preparation	1
2.4.1 Solvent Out-gassing and Sparging	1
2.4.2 Cavitation	2
2.4.3 Filtration	3
2.4.4 Solvents With Harmful Effects.....	3
2.5 Instrument Installation	3
2.5.1 Mobile Phase Reservoirs	3
2.5.2 Self-Flush Solution	4
2.5.3 Inlet Tubing and Filters.....	5
2.5.4 Outlet Tubing.....	5
2.5.5 Priming the Pump and the Flushing Lines	5
2.5.6 Long Term Pressure Calibration Accuracy.....	5
2.6 Preparation for Storage or Shipping	6
2.6.1 Isopropanol Flush.....	6
2.6.2 Packaging for Shipping	6

3. OPERATION	1
3.1 Front Panel Controls and Indicators	1
3.1.1 Prime/Purge Valve	1
3.1.2 Filter/Outlet.....	2
3.1.3 Control Panel	2
3.2 Rear Panel Remote Input	5

4. THEORY OF OPERATION	1
4.1 Mechanical Operation	1
4.1.1 Liquid System Flow Path.....	1
4.1.2 Pump Cycle.....	1
4.1.3 Pulse Damping.....	1
4.2 Electronic Control	1

4.2.1	Microprocessor Control	1
4.2.2	DC Power Supply	2
4.2.3	Remote Interfacing	2
4.2.4	Motor Stall Detector	2
<hr/>		
5.	MAINTENANCE.....	1
5.1	Filter Replacement.....	1
5.1.1	Inlet Filters.....	1
5.1.2	Outlet Filter.....	1
5.2	Changing Pump Heads.....	2
5.2.1	Removing the Pump Head.....	2
5.2.2	Cleaning the Pump Head Assembly	5
5.2.3	Replacing Piston Seals	6
5.2.4	Changing the Piston.....	8
5.2.5	Replacing the Pump Head	8
5.3	Conditioning New Seals	9
5.4	Check Valve Cleaning.....	9
5.5	Pulse Damper Replacement.....	9
5.5.1	Removing the Pulse Damper	9
5.5.2	Pulse Damper Refurbishing	10
5.5.3	Pulse Damper Installation	10
5.6	Cleaning the Pump.....	10
5.7	Cleaning the cabinet.....	11
5.8	Lubrication.....	11
5.9	Fuse Replacement	12
<hr/>		
7.	REPLACEMENT PARTS.....	1
<hr/>		
APPENDIX A.....		1
A.1	Rear Panel Serial Communications Port.....	1
A.1.1	Hardware Implementation.....	1
A.1.2	Hand-Shaking	2
A.1.3	Command Interpreter.....	2
A.2	Rear Panel 4-Pin and 10-Pin Terminal Board Connectors.....	4
A.2.1	Pressure Fault and Motor Stall Fault Output.....	4
A.2.2	General Information on Inputs	6
A.2.3	General Information on Run, Stop, and Enable Inputs	6
A.2.4	Run and Stop Inputs	6
A.2.5	Enable Input.....	7
A.2.6	General Information on Voltage and Frequency Inputs	7
A.2.7	Voltage Input.....	8
A.2.8	Frequency Input.....	8

A.1 Rear Panel Serial Communications Port.....A-1

A.1.1 Hardware Implementation.....A-1

A.1.2 Hand Shaking.....A-1

A.1.3 Command Interpreter.....A-2

A.2 Rear Panel 4-Pin and 10 Pin Terminal Board Connectors.....A-4

A.2.1 Pressure Fault and Motor Stall Fault Output.....A-4

 A.2.1.1 Upper and Lower Pressure Limit Range.....A-5

A.2.2 General Information on Inputs.....A-6

A.2.3 General Information on Run, Stop, and Enable Inputs.....A-6

A.2.4 Run and Stop Inputs.....A-6

A.2.5 Enable Input.....A-7

A.2.6 General Information on Voltage and Frequency Inputs.....A-7

A.2.7 Voltage Input.....A-7

A.2.8 Frequency Input.....A-8

1. INTRODUCTION

This operator's manual contains information needed to install, operate, and perform user maintenance on the Prep 36 HPLC Pump.

1.1 Description of the Prep Pump

The Prep 36 high performance liquid chromatography (HPLC) pump is designed to be a reliable component within basic analytical or sophisticated research instruments. While ideal for HPLC applications, the Prep 36 pump is also useful as a metering pump for general laboratory or industrial use.

The flowrate of the Prep pump fitted with two standard 12 mL pump heads can be set in 0.01 mL/min increments from 0.01 to 36.0 mL/min. It is available in type 316 stainless steel or biocompatible (metal-free) PEEK™.

1.1.1 Pump Features

The Prep 36 Pump:

- Incorporates a diaphragm-type pulse damper, which reduces pulsation in the system by as much as 90% and includes an isolated pressure transducer (i.e., the transducer adds no dead volume).
- Automatically turns the pump OFF if the pressure exceeds the maximum pressure limit determined by the pump head type (6000 psi for the stainless steel pump heads; 5000 psi for PEEK™ pump heads). The operator may program upper and lower pressure limits within the maximum range set by the pump head type.
- Integrated prime/purge valve.
- Autoflush™ piston wash, self-flushing pump head.
- Autoprime™ one button toggles flowrate to maximum for rapid solvent change
- Inlet and outlet check valves assure reliability
- Outlet filter
- Chemically-resistant LED readout on the front panel—shows the flow rate and pressure limits.
- Tactile response, chemically resistant front panel keypad.
- Microprocessor advanced control.

- Digital stepper motor design prevents flow rate drift over time and temperature, which is a common problem found in analog design.
- Back panel USB and RS232 serial communication ports for complete control and status monitoring.

1.1.2 Wetted Materials

Pump heads, check valve bodies, and tubing are made of type 316 stainless steel or PEEK™, depending on version ordered. Other materials common to either stainless steel or PEEK™ models are synthetic ruby and sapphire (check valve internals and piston) and fluorocarbon (damper diaphragm).

1.1.3 Self-Flushing Pump Heads

Self-flushing pump heads provide continuous washing of the piston surface without the inconvenience of a manual flush or gravity feed arrangement. The self-flushing pump head uses a secondary seal and set of check valves to create a continuous and positive flow in the area behind the high-pressure pump seal. The flushing solution washes away buffer salts that have precipitated onto the piston. If not removed, these precipitates can abrade the high-pressure seal and cause premature seal failure or leakage, and can possibly damage the pump.

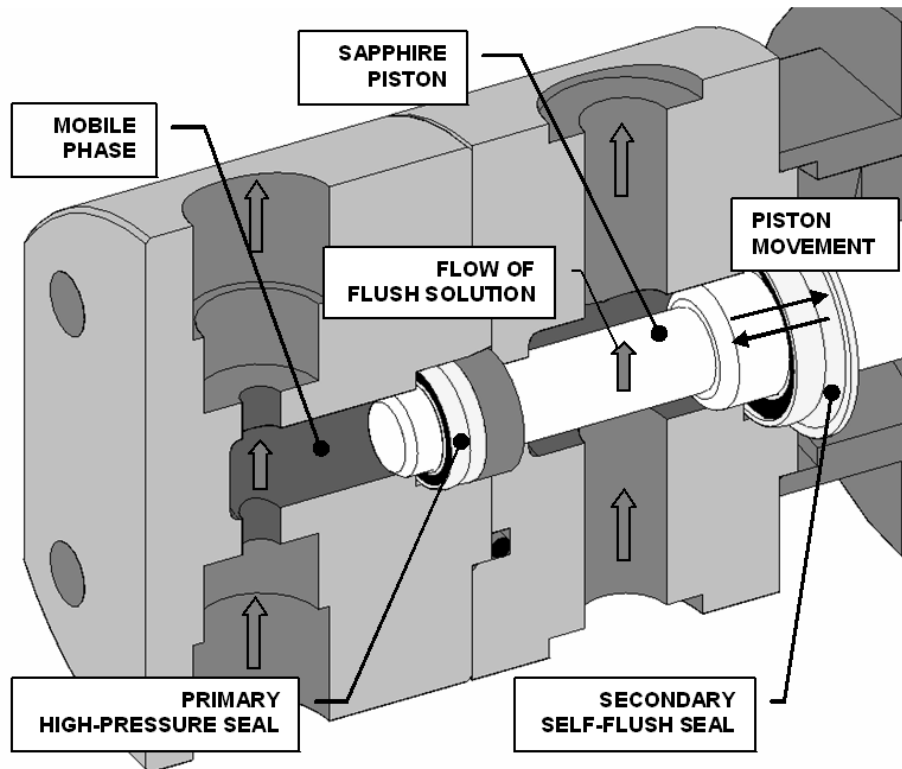

Figure 1-1. Self-Flushing Pump Head

1.1.4 Self-Flush and Seal Life

It is recommended that the Self Flush feature be used to improve seal life in a number of applications. In particular, (as stated above) if pumping Buffers, Acids/Bases or any inorganic solution near saturation, the pump should utilize the Self Flush feature. With every piston stroke, an extremely thin film of solution is pulled back past the seal. If this zone is dry (without use of Self Flush), then crystals will form with continuous operation, which will ultimately damage the seal.

Another application where Self Flush is highly recommended is when pumping Tetrahydrofuran (a.k.a. THF, Diethylene Oxide) or other volatile solvents such as acetone (Note: THF and most solvents are compatible only with all-Stainless Steel systems. THF will attack PEEK). Volatile solvents will dry rapidly behind the seal (without the use of Self Flush), which will dry and degrade the seal.

IPA, Methanol, 20% IPA/water mix or 20% Methanol/water mix are good choices for the flush solution. Consult the factory for specific recommendations.

2. INSTALLATION

2.1 Unpacking and Inspection

Prior to opening the shipping container, inspect it for damage or evidence of mishandling. If it has been damaged or mishandled, notify the carrier before opening the container. Once the container is opened, inspect the contents for damage. Any damage should be reported to the carrier immediately. Save the shipping container. Check the contents against the packing list.

2.2 Location/Environment

The preferred environment for the Prep pump is normal laboratory conditions. The area should be clean and have a stable temperature and humidity. The instrument should be located on a stable flat surface with surrounding space for ventilation and the necessary electrical and fluid connections. (Reference IEC 1010 installation category II, and Pollution degree 2 environment.)

2.3 Electrical Connections

Unpack the Prep pump; position the pump so there is at least a four inch clearance on all sides to permit proper ventilation. Then plug the pump into a properly grounded electrical outlet.

WARNING: Do not bypass the safety ground connection as a serious shock hazard could result.

2.4 Solvent Preparation

Proper solvent preparation will prevent a great number of pumping problems. The most common problem is bubble formation, which may affect the flow rate consistency. Aside from leaky fittings, the problem of bubble formation arises from two sources: solvent out-gassing and cavitation. Filtration of HPLC solvents is also required.

2.4.1 Solvent Out-gassing and Sparging

Solvent out-gassing occurs because the mobile phase contains dissolved atmospheric gases, primarily N₂ and O₂. These dissolved gases may lead to bubble formation and should be removed by degassing the mobile phase before or

during use. The best practical technique for degassing is to sparge the solvent with standard laboratory grade (99.9+%) helium. Helium is only sparingly soluble in HPLC solvents, so other gases dissolved in the solvent diffuse into the helium bubbles and are swept from the system. Solvent filtration is not an effective alternative to helium degassing.

It is recommended that you sparge the solvent vigorously for 10 to 15 minutes before using it. Then maintain a trickle sparge during use to keep atmospheric gases from dissolving back into the mobile phase. The sparged solvent must be continually blanketed with helium at 2 to 3 psi. Non-blanketed sparged solvents will have atmospheric gases dissolved back into the mobile phase within four hours.

Solvent mixtures using water and organic solvents (like methanol or acetonitrile) hold less dissolved gas than pure solvents. Sparging to reduce the amount of dissolved gas is therefore particularly important when utilizing solvent mixture.

Even with sparging some out-gassing may occur. A backpressure regulator installed after the detector flow cell will help prevent bubbles from forming and thus limit baseline noise.

WARNING: Always release pressure from the pump slowly. A rapid pressure release could cause the pulse damper diaphragm to rupture.

2.4.2 Cavitation

Cavitation occurs when inlet conditions restrict the flow of solvent and vapor bubbles are formed during the inlet stroke. The key to preventing cavitation is to reduce inlet restrictions. The most common causes of inlet restrictions are crimped inlet lines and plugged inlet filters. Inlet lines with tubing longer than 48" (120 cm) or with tubing of less than 0.085" (2 mm) ID may also cause cavitation.

Placing the solvent reservoirs below the pump level also promotes cavitation. The optimal location of the reservoirs is slightly above the pump level, but it is adequate to have them on the same level as the pump.

2.4.3 Filtration

Solvent filtration is good practice for the reliability of the Prep pump and other components in a HPLC system. Solvents should always be filtered with a 0.5 micron filter prior to use. This ensures that no particles will interfere with the reliable operation of the piston seals and check valves. Solvents in which buffers or other salts readily precipitate out will need to be filtered more often. After filtration, the solvents should be stored in a closed, particulate-free bottle.

2.4.4 Solvents With Harmful Effects

Except for PEEK™ pump heads, all portions of the Prep pump that contact mobile phase are manufactured of type 316 stainless steel, sapphire, ruby, or fluorocarbon polymer. Some of these materials are extremely sensitive to acids (including some Lewis acids) and acid halides. Avoid using solvents that contain any amount of hydrochloric acid.

Some solvents you should specifically avoid are:

Aqua Regia	Hydrochloric Acid
Bromine	Hydrofluoric Acid
Chlorine Anhydrous	Hydrofluorsilicic Acid
Copper Chloride	Hydrogen Peroxide
Ferric Chloride	Iodine
Ferrous Chloride	Mercuric Chloride
Freon 12 (wet)	
Guanidine	
Hydrobromic Acid	

In addition, some users of HPLC systems have observed that chloroform and carbon tetrachloride slowly decompose to liberate hydrochloric acid, which, as noted above, attacks stainless steel. Do not leave these solvents in the systems for a prolonged period.

You may also want to avoid ammonium hydroxide. Although ammonium hydroxide will not harm the pump itself, it is likely to damage the stator and rotor in injection valves.

2.5 Instrument Installation

2.5.1 Mobile Phase Reservoirs

The mobile phase reservoir should be placed at the same level or slightly higher than the pump, never below the pump, and the inlet tubing should be as short as practical. These steps

minimize pressure losses on the inlet side of the pump during refill and help to avoid bubble formation. These steps are particularly important when using high vapor pressure solvents (hexane, methylene chloride, etc.). Mobile phases should be degassed, filtered and covered. (See Section 2.4.)

2.5.2 Self-Flush Solution

Self-flush heads require 250-500 mL of flushing solution. See section 1.1.4 for self-flush solution recommendations. A pH indicator that will indicate the concentration of salts in the solution is recommended as a reminder to change the solution. This flush solution should be replaced with a fresh solution weekly to avoid frequent pump maintenance.

WARNING: If you do not use the self-flush feature of this pump, you must carefully remove the self-flush seal with the seal tool provided and place the seal into the guide bushing bag. Replace the flush seal with the guide bushing provided (See illustration below). If this is not done; low flow rates, excessive noise and shortened pump life will result.

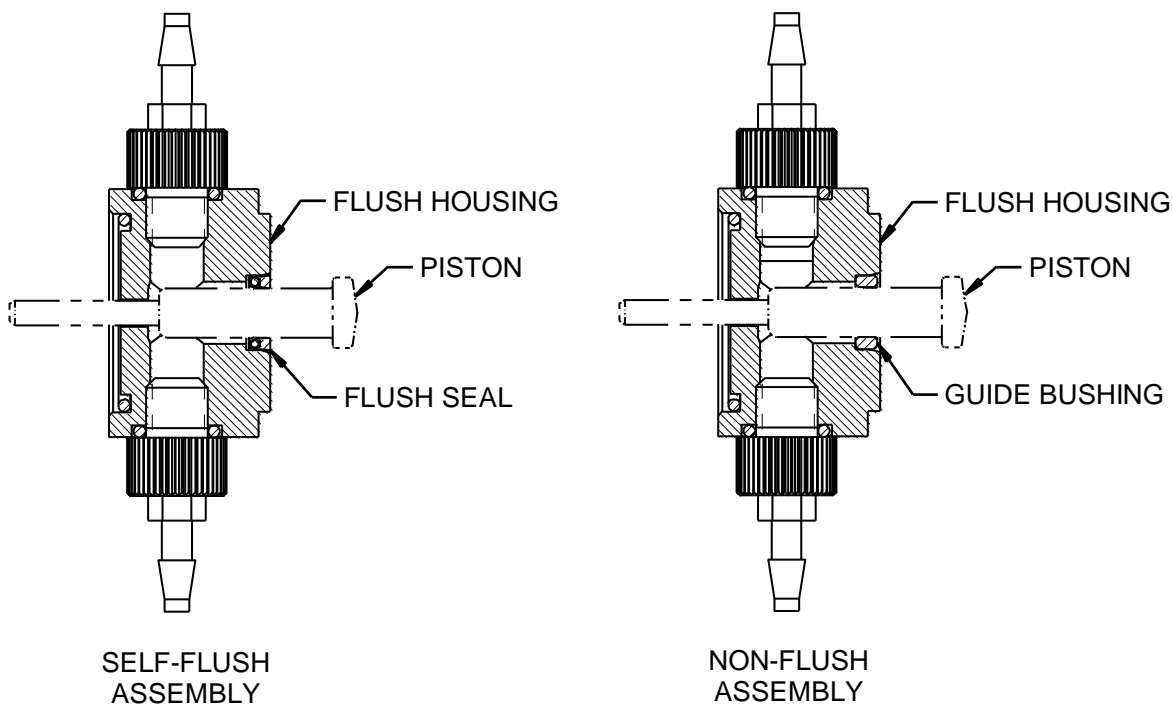

2.5.3 Inlet Tubing and Filters

All inlet lines are supplied in a 36" (91 cm) length, with a 0.085" ID and a 1/8" OD., and are made of a Teflon-based material. Use a 0.5 micron slip-on inlet filter.

2.5.4 Outlet Tubing

Outlet tubing (not supplied with the pump) should have a 1/16" outer diameter. It is available in type 316 stainless steel, or PEEK™. When using PEEK™ tubing at elevated pressures, (2,500 psi and above), it is recommended to use tubing with a 0.020" inner diameter. The tubing must be cut squarely with no burrs. The tube itself should not be crimped and the center hole must be open. A tubing cutter is recommended for cutting stainless steel tubing. PEEK™ tubing may be cut with a plastic tubing cutter or razor knife.

2.5.5 Priming the Pump and the Flushing Lines

Be sure all of the connections downstream of the prime/purge valve are closed. Connect a syringe to the prime/purge valve. Open the prime/purge valve 1 to 2 turns (counter-clockwise). Run the pump at a flow rate of 3 to 5 mL/min. Prime the pump by pulling mobile phase and any air bubbles through the system and into the syringe (a minimum of 20 mL). Close the prime/purge valve and stop the pump.

To prime the flush lines for a self-flush head, connect one of the small Luer-to-barb fittings to a syringe and pull 10-20 mL of flush solution through the outlet line (at the top of the pump head).

2.5.6 Long Term Pressure Calibration Accuracy

This note applies if your pump is equipped with an electronic pressure transducer. The transducer has been zeroed and calibrated at the factory. Over the life of the pump, some drift may occur. For example, it is typical for the zero to drift < 10 psi. after about 1 year of operation (i.e., with no back pressure on the pump a reading of 1-9 psi. may be displayed). A similar drift may also occur at higher pressures, and are typically less than 1% (e.g. <50 psi. at 6,000 psi. back pressure).

If pressure calibration and/or drift are a concern, consult the factory. The pump can be shipped back to SSI for recalibration.

Alternatively, written calibration and zero-reset procedures are available. Consult the factory to receive these instructions.

2.6 Preparation for Storage or Shipping

2.6.1 *Isopropanol Flush*

Disconnect the outlet tubing from the pump. Insert the inlet filter in isopropanol. Open the prime/purge valve and use a syringe to draw a minimum of 50 mL. Close the prime/purge valve and pump a minimum of 5 mL of isopropanol to exit. Leave the inlet tubing connected to the pump. Place the inlet filter in a small plastic bag and attach it to the tubing with a rubber band. Plug the outlet port with the shipping plug, leave a length of outlet tubing on the pump, or cover the outlet port with plastic film.

2.6.2 *Packaging for Shipping*

CAUTION: Re-package in the original carton, if possible. If the original carton is not available, wrap the pump in several layers of bubble wrap and cushion the bottom, top, and all four sides with 2" of packaging foam. Although heavy, an HPLC pump is a delicate instrument and must be carefully packaged to withstand the shocks and vibration of shipment.

3. OPERATION

3.1 Front Panel Controls and Indicators

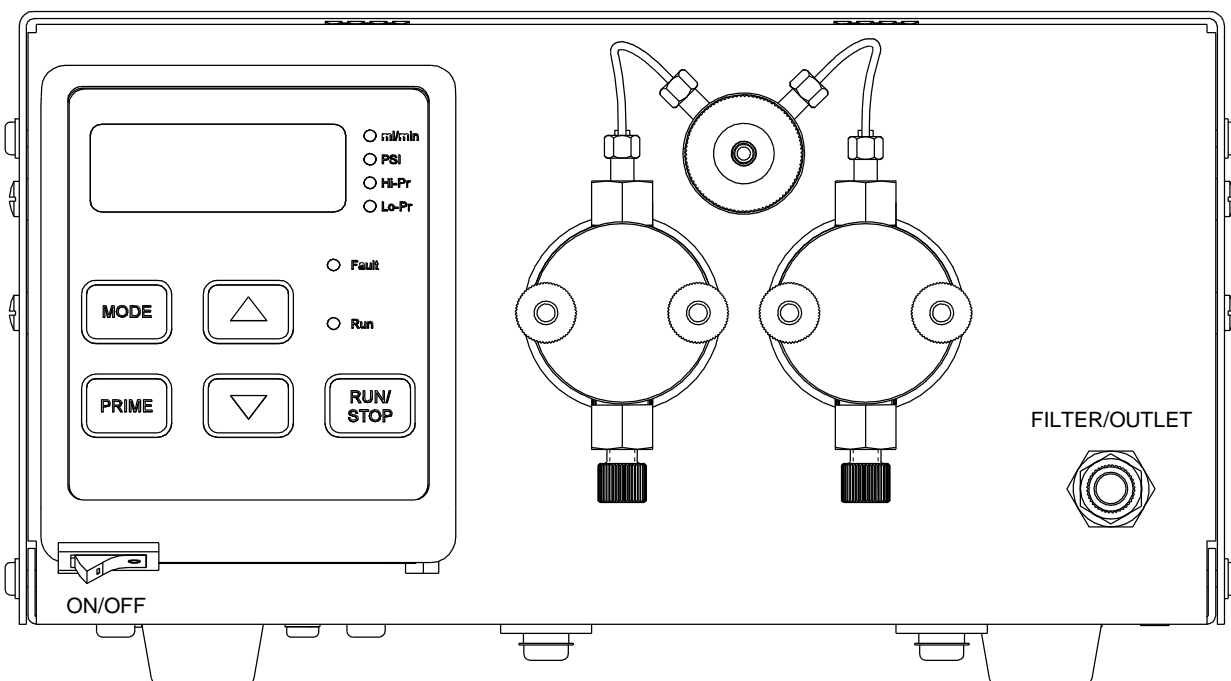

Figure 3-1. Prep Pump Front Panel

3.1.1 Prime/Purge Valve

CAUTION: When you press the PRIME key, the pump will run at the maximum flow rate. Be sure the prime/purge valve is open.

The prime/purge valve vents the flow to atmosphere and permits efficient priming of the Prep pump. When the valve is closed (fully clock-wise) firmly, high-pressure flow is directed to the Filter/Outlet port. When the valve is opened (counter clock-wise) one-half to one full turn, pressure is vented and flow exits through the drain port in the prime/purge valve stem assembly. Suction with a Luer tip syringe at the drain port will purge air bubbles from the pump and reservoir lines (provided there are no open valves to lines downstream at the injector/column interface). To prime the pump, draw about 20 to 30 mL of mobile phase.

3.1.2 Filter/Outlet

A high-pressure in-line filter (2.0 micron rating) is included at the output of the Prep pump. The Filter/Outlet port is the high-pressure filter closure and is designed for a 1/16" OD tubing connection.

3.1.3 Control Panel

3.1.3.1 Digital Display

The 4-digit display shows the pump flow rate (mL/min), system pressure (psi), or the set upper or lower pressure limit (psi) when operating. Choice of display is selected with the MODE key.

3.1.3.2 Keypad

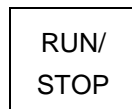

When pressed, this button alternately starts and stops the pump.



When pressed, this button increases the flow rate.

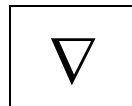

When pressed, this button decreases the flow rate.

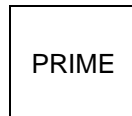

When the PRIME button is pressed, the pump runs at the maximum flow rate for the pump head. It will stop when any button is pressed.

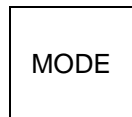

Use this button to cycle through the four display modes: flow rate, pressure, upper pressure limit, or lower pressure limit. A status LED to the right of the digital display indicates which mode is active.

Fast And Slow Button Repeat On The Up And Down Arrow Buttons: If the UP-ARROW or DOWN-ARROW button is held down for more than approximately one half of a second, the button press will repeat at a slow rate of approximately 10 times a second. Once slow button repeat has begun, fast button repeat can be initiated by using a second finger to press down the second arrow button. During fast button repeat, the button press will repeat at a rate of approximately 100 times a second. Switching back and forth between repeat speeds can be accomplished by pressing and releasing the second arrow button while keeping the first arrow button held down.

3.1.3.3 Status LEDs

ML/MIN	When lit, the digital display shows flow rate in mL/min.
PSI	When lit, the digital display shows system pressure in psi.
HI PRESS	When lit, the display shows the user-set upper pressure limit in psi.
LO PRESS	When lit, the display shows the user-set lower pressure limit in psi.
PUMP RUN	Lights to indicate that the pump is running.
FAULT	Lights when a fault occurs and stops the pump.

3.1.3.4 Power-up Configuration

Pressure Compensation: On power-up, press the PRIME button on the front panel while pressing the Power On switch under the front display panel. The pump will display a number from 0 to 60. This represents the running pressure of the pump from 0 psi to 6000 psi. Each digit represents 100 psi. To change the pressure compensation number use the up arrow and down arrow buttons. When you have selected the correct pressure compensation press the RUN button to return to normal operation of the pump.

Non-volatile Memory Reset: If the pump is operating erratically, there is the possibility that the memory has been corrupted. To reset the memory and restore the pump to its default parameters, press and hold the UP-ARROW button when the power is switched on. Release the button when the display reads "rES". The parameters stored in non-volatile memory, i.e., the flow rate, the pressure compensation, the voltage/frequency select, the lower pressure limit, and the upper pressure limit will be set to the factory default values. The head type setting is the only parameter not changed by the non-volatile memory reset function. If the firmware is upgraded to a newer version, a non-volatile memory reset will automatically occur the first time the power is switched on.

3.1.3.5 Power-Up Tests

Display Software Version Mode: The software version can be displayed during power-up by pressing and holding the RUN/STOP and the UP-ARROW buttons when the power is switched on. Release the buttons when the display reads "UEr". The decimal point number displayed on the display is

the software version. To exit this mode, press the RUN/STOP button.

Display Software Checksum Mode: If the pump is operating erratically, there is the possibility that the firmware stored in the program memory integrated circuit (EPROM) has been corrupted. Each version of firmware has a checksum which is printed on the EPROM's label. The pump's cover must be removed to gain access to the EPROM which is located on the Pump Control Board; therefore, this should be only done by a qualified technician. To verify that the firmware has not been corrupted, do the following: The software checksum can be displayed during power-up by pressing and holding the RUN/STOP and the DOWN-ARROW buttons when the power is switched on. Release the buttons when the display reads "CHE". After approximately 25 seconds, the 4-digit hexadecimal checksum will be displayed. To exit this mode, press the RUN/STOP button. If the checksum displayed does not match the checksum printed on the EPROM's label, the EPROM must be replaced. Note: If the pump is operating correctly, the firmware version and checksum can be displayed then written in the manual for future comparison. This will save time during future troubleshooting since the pump's cover will not have to be removed to read the EPROM's label.

Align Refill Switch Mode: The signal that initiates the refill phase can be displayed during power-up by pressing and holding the PRIME and the UP-ARROW buttons when the power is switched on. Release the buttons when the display displays "rFL". When the slotted disk allows the light beam to pass from the emitter to the detector on the slotted optical switch a pulse will be generated which signals the beginning of refill. When this pulse occurs the three horizontal segments displayed at the top of the display will turn off and the three horizontal segments at the bottom of the display will turn on. To exit this mode, press the RUN/STOP button.

Serial Port Loop back Test Mode: If an external device will not communicate to the pump via the serial port, the serial port loop back test can be used to verify that the serial port is functioning properly. During power-up press and hold the UP-ARROW and the DOWN-ARROW buttons when the power is switched on and then release the buttons. The display must display "C00" for the first half of the test to pass. Plug in the serial port loop back plug (A modular plug with pins 2 & 5 jumpered together and pins 3 & 4 jumpered together.). The

display must read "C11" for the second half of the test to pass. To exit this mode, press the RUN/STOP button.

3.2 Rear Panel Remote Input

USB and RS-232C ports are provided on the back panel. A computer with appropriate software can be used as a remote control device for pump operation via this connection. The USB interface has precedence, and when connected will disable RS-232 communication.

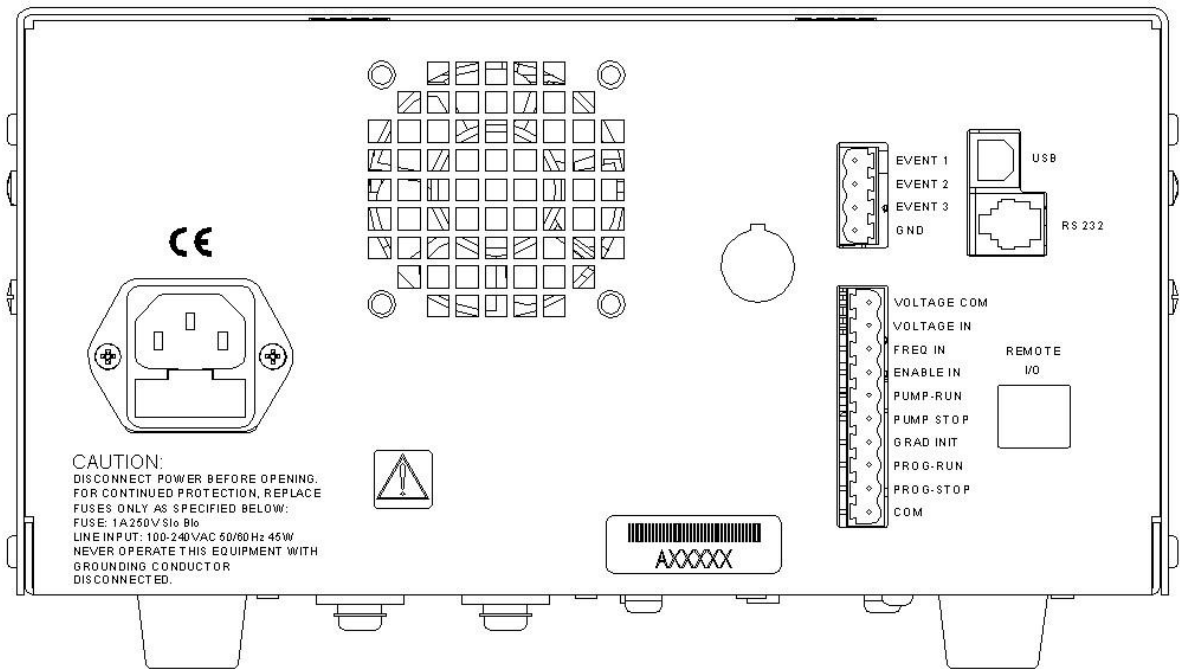

Figure 3-2. Prep Pump Rear Panel

Note: For external connections and serial communications see Appendix A in back of manual.

4. THEORY OF OPERATION

4.1 Mechanical Operation

4.1.1 *Liquid System Flow Path*

The flow path of the Dual Head pump starts at the inlet of the pump head, passes through the pump head and through the prime/purge valve, into the pulse damper then finally through the bulkhead filter and out the front panel of the pump.

4.1.2 *Pump Cycle*

The pump cycle consists of two phases, the pumping phase and the refill phase.

During the operation of the pump, one pump piston displaces fluid at a constant rate from one head, while the other piston is refilling the other pump head with fluid. When that piston is finished displacing fluid, the other piston immediately starts. This results in a constant, stable flow from the pump at high pressure.

4.1.3 *Pulse Damping*

The diaphragm-type pulse damper consists of a compressible fluid (isopropanol) held in an isolated cavity by an inert but flexible diaphragm. During the pumping phase of the pump cycle, the fluid pressure of the mobile phase displaces the diaphragm, compressing the fluid in the cavity and storing energy. During the pump refill phase the pressure on the diaphragm is reduced and the compressed fluid expands, releasing the energy it has stored. This helps to stabilize flow rate and pressure. The amount of mobile phase in contact with the pulse damper is small, only 1.2 mL at 6,000 psi, and the geometry used insures that the flow path is completely swept, so solvent “memory effects” are virtually eliminated.

4.2 Electronic Control

4.2.1 *Microprocessor Control*

The pump is controlled by hybrid microprocessor circuitry which (1) provides control signals to the motor power board, (2) interfaces with the keyboard/display, (3) receives signals from the pressure transducer and refill flag, and (4) provides external input/output and remote control interfacing. Firmware programming is stored in an EPROM.

The motor power board contains programmed logic components which (1) provide suitable motor micro-stepping modes, (2) allow appropriate motor power adjustment, (3) maximize motor power output, (4) reduce motor resonance effects, and (5) customize motor stepping uniformity. MOSFET power transistors efficiently control the motor power provided by a 48 Vdc linear power supply. This board also provides the 12 Vdc (linear power supply) and the 5 Vdc (switching power supply) used by the pump circuits.

The flow rate of any high-pressure pump can vary depending on the operating pressure and the compressibility of the fluid being pumped. The pump is calibrated at 1,000 psi using an 80:20 mixture of water and isopropanol.

The pulse damper of the Prep pump has a built-in pressure transducer, which senses fluid pressure. The output is sent to the microprocessor circuit, which provides the information presented on the digital display. This pressure information is compared with the user-set upper and lower pressure limits to control pump shut-off if the limits are exceeded.

4.2.2 DC Power Supply

A switching regulator provides the DC voltage necessary to run the motor and electronics. AC input power for the pump must be between 85 and 265 VAC, and 47 to 63 Hz. The AC line is filtered and fused by the power entry module. Internally a fuse located on the Motor Drive PCB protects the motor supply voltage, and the low voltage conversions have thermal and short-circuit protection.

4.2.3 Remote Interfacing

USB and RS-232C ports are provided on the back panel. See Section 3.2 for information on pump operation via this connection.

4.2.4 Motor Stall Detector

The motor can stall and create a loud buzzing sound if the flow path connected to the pump's outlet becomes plugged, if the pressure exceeds the maximum pressure rating of the pump, or if the mechanism jams. In the event a motor stall occurs, the electrical current being supplied to the motor is turned off and the fault light is turned on.

The Motor Stall Detector is enabled or disabled during power-up by pressing and holding the RUN/STOP and the

PRIME buttons when the power is switched on. Release the buttons when the display displays "SFE". To enable the Motor Stall Detector press the UP-ARROW button and the display will display "On". To disable the Motor Stall Detector press the DOWN-ARROW button and the display will display "OFF". To exit this mode and store the current setting in non-volatile memory, press the RUN/STOP button.

The Motor Stall Detector uses a timer to determine if the camshaft has stopped turning or if the refill switch is defective. The timer begins timing after the pump accelerates or decelerates to its set-point flow rate. If the Motor Stall Detector has been enabled, and the cam shaft stops turning or the refill switch stops operating, the fault will be detected between the time it takes to complete 1 to 2 pump cycles. A pump cycle is defined as the time it takes for the camshaft to complete one complete revolution. One revolution of the camshaft produces a delivery phase and a refill phase. Each specific flow rate has a corresponding cycle time. The cycle time is approximately: 30 seconds at 0.2 mL/min, 3 seconds at 2.4 mL/min, and 0.3 seconds at 24.00 mL/min.

The fault is canceled by using one of the following methods: (1) by pressing the RUN/STOP button on the front panel, (2) by sending a stop command "ST" via the serial communications port on the back panel, or (3) by connecting the PUMP-STOP input to COM on the back panel, or removing the connection between the PUMP-RUN input and COM if the PUMP-STOP input is permanently jumpered to COM on the back panel. Note: the PUMP-RUN, PUMP-STOP, and COM are an option and do not exist on the standard pump.

5. MAINTENANCE

Cleaning and minor repairs of the Prep pump can be performed as outlined below.

Note: Lower than normal pressure, pressure variations, or leaks in the pumping system can all indicate possible problems with the piston seal, piston, or check valves. Piston seal replacement could be necessary after 1,000 hours of running time. See Section 5.2.3.

5.1 Filter Replacement

5.1.1 Inlet Filters

Inlet filters should be checked periodically to ensure that they are clean and not restricting flow. A restriction could cause cavitation and flow loss in the pump. Two problems that can plug an inlet filter are microbial growth and impure solvents. To prevent microbial growth, use at least 10-20% organic solvent in the mobile phase or add a growth-inhibiting compound. If you pump 100% water or an aqueous solution without any inhibitors, microbes will grow in the inlet filter over time, even if you make fresh solution every day. Always use well filtered, HPLC grade solvents for your mobile phase.

5.1.2 Outlet Filter

To service the outlet filter on stainless steel pumps:

1. Unscrew the filter closure from the filter housing.

CAUTION: Do not use a metal object such as a screwdriver or paperclip to remove the seal. Doing so can scratch the precision surface of the seat and may cause the filter to leak.

2. Use a seal insertion/removal tool or a non-metallic object (such as a wooden toothpick) to remove the large seal that remains in the housing.
3. Unscrew the old filter and remove the small seal from the filter closure.
4. Place one of the small seals included in the replacement element kit over one of the new filters from the kit. Screw the new filter into the filter closure (finger tight).

5. Place one of the large seals from the replacement kit on the filter closure. Insert the filter closure into the housing and tighten.

To service the PEEK™ outlet filter, simply open the filter housing and clean or replace the filter element inside.

5.2 Changing Pump Heads

5.2.1 Removing the Pump Head

As a guide to pump head assembly, the standard pump heads are shown in Figures 5-1 through 5-4. All of the Prep pump heads have a similar arrangement.

1. Turn OFF the power to the Prep pump.
2. Remove the inlet line and filter from the mobile phase reservoir. Be careful not to damage the inlet filter or crimp the Teflon™ tubing.
3. Remove the inlet line from the inlet check valve.
4. Remove the outlet line from the outlet check valve.
5. Remove inlet and outlet self-flush lines.
6. Momentarily turn ON the Prep pump and quickly turn OFF the power upon hearing the refill stroke. This reduces the extension of the piston and decreases the possibility of piston breakage.
7. Unplug the power cord.
8. Carefully remove the two knurled nuts at the front of the pump head.

CAUTION: Be careful not to break the piston when removing the pump head. Twisting the pump head can cause the piston to break.

9. Carefully separate the pump head from the pump. Move the pump head straight out from the pump and remove it from the piston. Be careful not to break or damage the piston. Also remove the seal and seal backup washer from the piston if they did not stay in the pump head.
10. Carefully separate the flush housing from the pump. Move the flush housing straight out from the pump and remove it from the piston. Be careful not to break or damage the

piston. Also remove the self-flush seal from the piston if it did not stay in the flush housing.

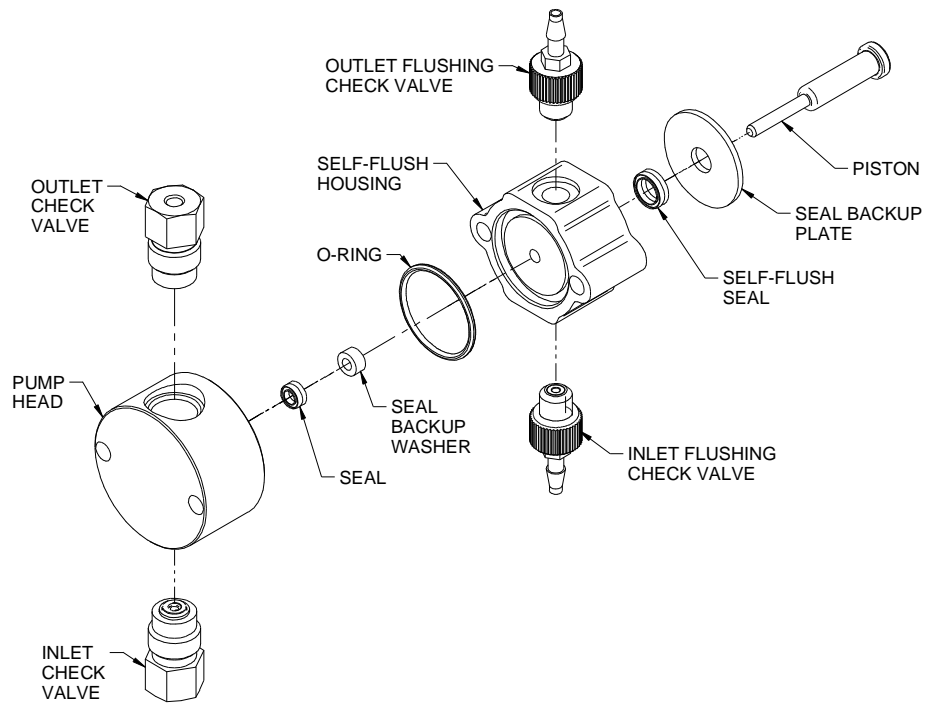

Figure 5-1. Stainless Steel Self-Flushing Pump Head Assembly

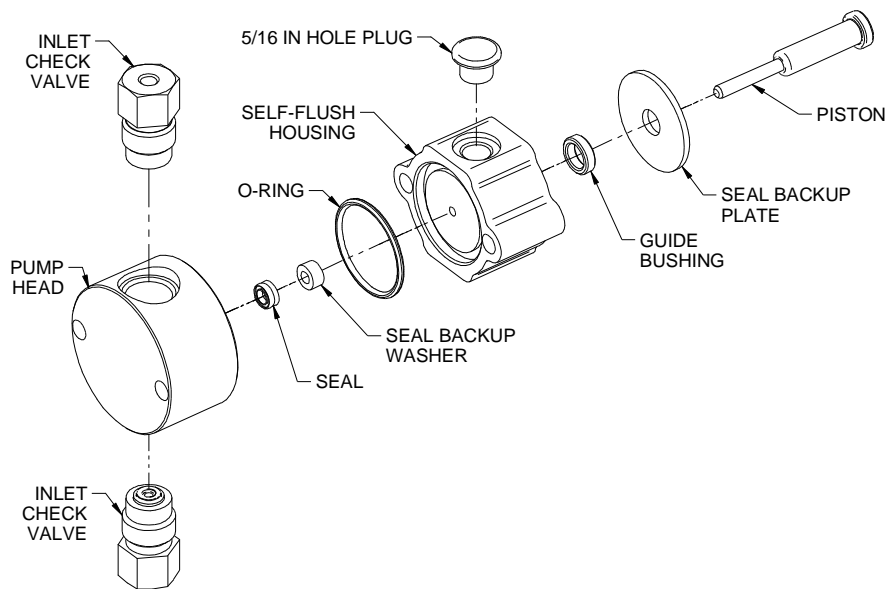

Figure 5-2. Stainless Steel Non-Self-Flushing Pump Head Assembly

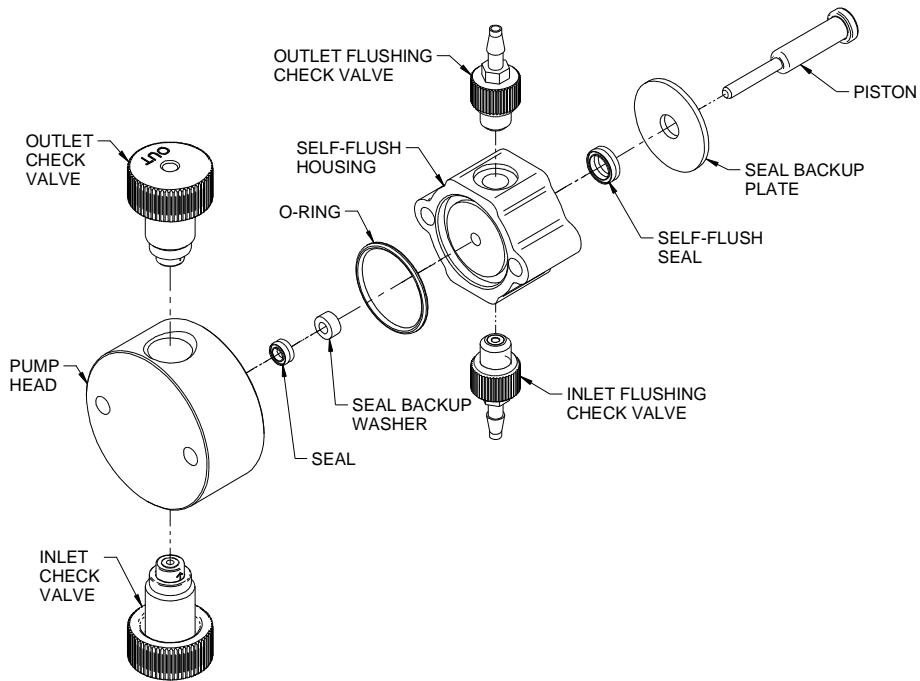

Figure 5-3. Bioclean (PEEK™) Self-Flushing Pump Head Assembly

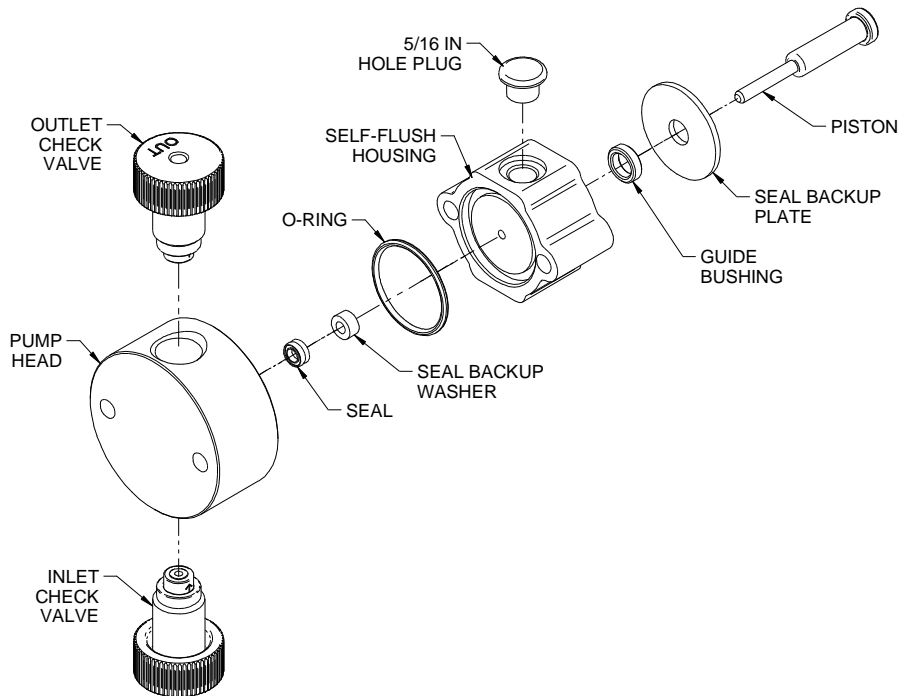

Figure 5-4. Bioclean (PEEK™) Non-Self-Flushing Pump Head Assembly

5.2.2 *Cleaning the Pump Head Assembly*

Note: If you choose to remove the piston seal or self-flush seals, you should have a new set on hand to install after cleaning. It is not recommended that you reinstall used piston or self-flush seals since they are likely to be scratched and damaged during removal and would not provide a reliable seal if reused. If you decide to remove the seals, use only the flanged end of the plastic seal removal tool supplied with the seal replacement kit and avoid scratching the sealing surface in the pump head. See Section 5.2.3 for seal replacement instructions.

1. Inspect the piston seal cavity in the pump head. Remove any foreign material using a cotton swab, or equivalent, and avoid scratching the sealing surfaces. Repeat for the self-flush housing. Be sure no fibers from the cleaning swab remain in the components.
2. The pump head, check valves, and self-flush housing may be further cleaned using a laboratory grade detergent solution in an ultrasonic bath for at least 30 minutes, followed by rinsing for at least 10 minutes in distilled water. Be sure that all particles loosened by the above procedures have been removed from the components before re-assembly.
3. If the check valves have been removed, tighten the check valves on stainless steel pumps to 75 inch-pounds or enough to seal at maximum pressure. For Bioclean (PEEK™) pumps, tighten each check valve to 10-15 inch-pounds.

Note: The inlet check valve has a larger opening (1/4"-28, flat-bottom seat) for the 1/8" inlet tubing; the outlet check valve has a smaller opening (#10-32, cone seat) for the 1/16" outlet tubing. For 10 mL heads only, the inlet check valve must be connected at the larger opening in the pump head. See Figure 5-5.

If the piston and flushing seals have been removed, insert new seals as described in Section 5.2.3, then continue with Section 5.2.5 to replace the pump head.

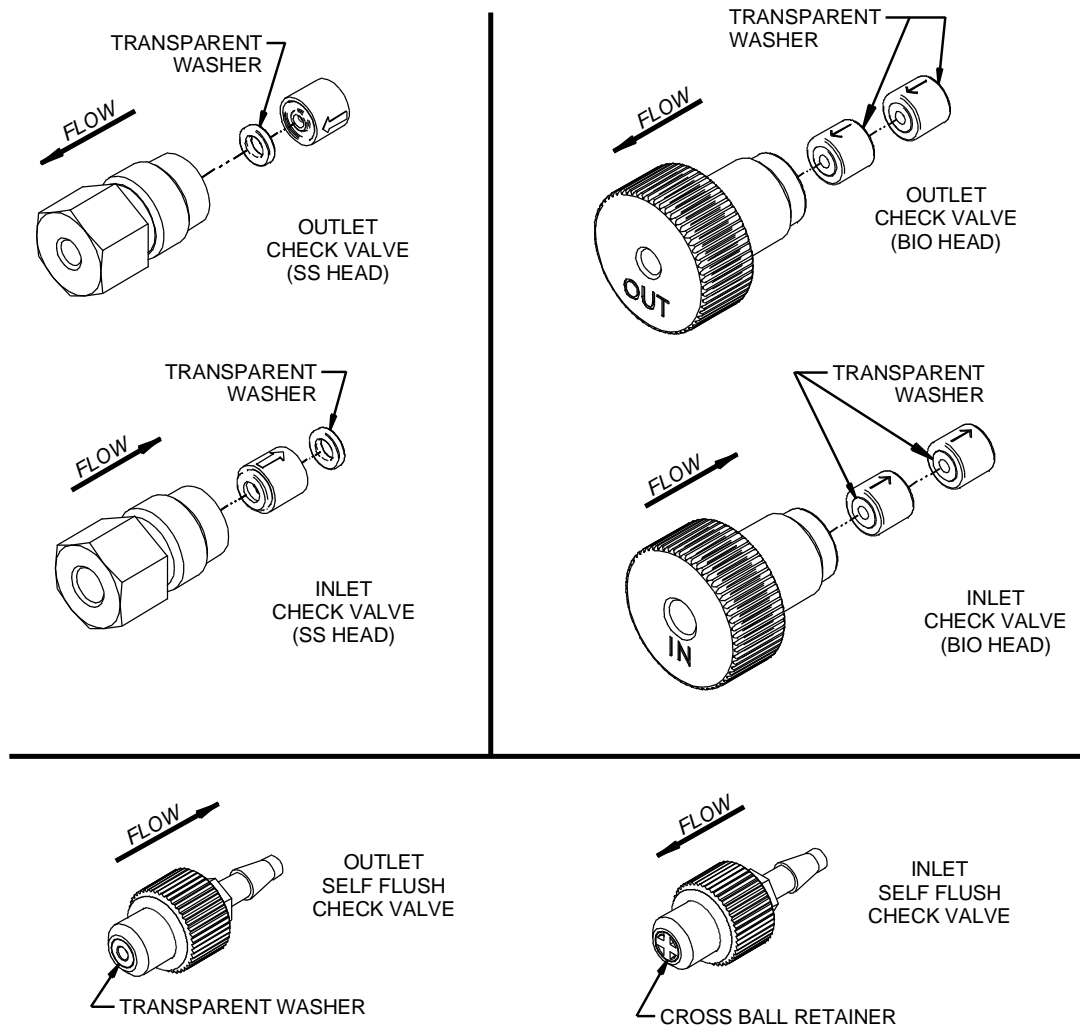

Figure 5-5. Check Valves

5.2.3 Replacing Piston Seals

Lower than normal pressure, pressure variations, and leaks in the pumping system can all indicate possible problems with the piston seal. Depending on the fluid or mobile phase used, piston seal replacement is often necessary after 1000 hours of running time.

Each replacement seal kit contains one seal, one backup washer, one self-flush seal, one non-flush guide bushing,

two seal insertion/removal tools, and a pad to clean the piston when changing the seal.

5.2.3.1 Removing the Seals

1. Remove the pump head as described in Section 5.2.1.
2. Insert the flanged end of the seal insertion/removal tool into the seal cavity on the pump head. Tilt it slightly so that flange is under the seal and pull out the seal.

CAUTION: Using any other “tool” will scratch the finish.

3. Repeat the procedure for the low-pressure seal in the flush housing.
4. Inspect, and if necessary, clean the pump head as described in Section 5.2.2.

5.2.3.2 Cleaning the Piston

1. Once the pump head and self-flush housing are removed, gently remove the seal back-up plate by using either a toothpick or small screwdriver in the slot on top of the pump housing.
2. Grasp the metal base of the piston assembly so that you avoid exerting any side load on the sapphire rod, and remove the piston from the slot in the carrier by sliding it up.
3. Use the scouring pad included in the seal replacement kit to clean the piston. Gently squeeze the piston within a folded section of the pad and rub the pad along the length of the piston. Rotate the piston frequently to assure the entire surface is scrubbed. Do not exert pressure perpendicular to the length of the piston, as this may cause the piston to break. After scouring, use a lint-free cloth, dampened with alcohol, to wipe the piston clean.
4. Grasp the metal base of the piston assembly, and insert it into the slot in the piston carrier until it bottoms in the slot.

5.2.3.3 Replacing the Seals

1. Place a high-pressure replacement seal on the rod-shaped end of the seal insertion/removal tool so that the spring is visible when the seal is fully seated on the tool. Insert the tool into the pump head so that the open side of the seal enters first, facing the high-pressure cavity of the pump

head. Be careful to line up the seal with the cavity while inserting. Then withdraw the tool, leaving the seal in the pump head. When you look into the pump head cavity, only the polymer portion of the seal should be visible.

2. Place a self-flush replacement seal on the seal insertion/removal tool so that the spring in the seal is visible when the seal is on the tool. As in the previous step, insert the tool and seal into the seal cavity on the flushing housing, taking care to line up the seal with the cavity, and then withdraw the tool. When the seal is fully inserted only the polymer part of the seal will be visible in the seal cavity.
3. Place seal back-up washer over the high-pressure seal. Place seal back-up plate back into pump housing if it was removed. Orientation is not important in these cases.
4. Attach the pump head as described in Section 5.2.5.
5. Condition the new seal as described in Section 5.3.

5.2.4 Changing the Piston

1. Remove the pump head as described in Section 5.2.1.
2. Grasp the metal base of the piston assembly so that you avoid exerting any side load on the sapphire rod, and remove the piston from the slot in the carrier by sliding it up.
3. Grasp the metal base of the replacement piston assembly, and insert it into the slot in the piston carrier until it bottoms in the slot.
4. Attach the pump head as described in Section 5.2.5.

5.2.5 Replacing the Pump Head

Refer to figures 5-1 through 5-4.

1. Make sure that the inlet valve is on the bottom and the outlet valve is on the top. Carefully align the self-flush housing and gently slide it into place on the pump. If misalignment with the piston occurs, gently push up on the piston holder.
2. Line up the pump head and carefully slide it into place. Be sure that the inlet valve is on the bottom and the outlet valve is on the top. Do not force the pump head into place.
3. Finger tighten both knurled nuts into place. To tighten firmly, alternately turn nuts 1/4 turn while gently wiggling the pump head to center it.

4. Re-attach the inlet and outlet lines. Reconnect the self-flush lines and fittings to the self-flush check valves. Change the flushing solution.

5.3 Conditioning New Seals

Note: Use only organic solvents to break-in new seals. Buffer solutions and salt solutions should never be used to break-in new seals.

Using a restrictor coil or a suitable column, run the pump with a 50:50 solution of isopropanol (or methanol) and water for 30 minutes at the back pressure and flow rate listed under PHASE 1 below and according to the pump head type. Then run the pump for 15 minutes at a backpressure and flow rate listed under PHASE 2 below.

Pump Head Type	PHASE 1		PHASE 2	
	Pressure	Flow Rate	Pressure	Flow Rate
12 mL SS/PEEK™	2000 psi	<3 mL/min.	3000-4000 psi	3-4 mL/min.

5.4 Check Valve Cleaning

Many check valve problems are the result of small particles interfering with the operation of the check valve. As a result, most problems can be solved by pumping a strong solution of liquid, laboratory grade detergent through the check valves at a rate of 1 mL/min for one hour. After washing with detergent, pump distilled water through the pump for fifteen minutes. Always direct the output directly to a waste beaker during cleaning. If this does not work, the check valve should be replaced.

5.5 Pulse Damper Replacement

Note: If you observe blue fluid leaking from the pump, the pulse damper has ruptured and must be replaced.

5.5.1 Removing the Pulse Damper

WARNING: There are potentially lethal voltages inside the pump case. Disconnect the line cord before removing the cover. Never bypass the power grounds.

1. Make certain that the system has been depressurized. Unplug the power cord and remove the cover.

2. Disconnect the tubing from the pulse damper.
3. Disconnect the transducer from the circuit board.
4. Remove the four screws that secure the pulse damper from the underside of the pump.
5. Remove the pulse damper.

5.5.2 Pulse Damper Refurbishing

Do not attempt to refill or refurbish the pulse damper until you have a refurbishing kit. Instructions are furnished with the kit.

5.5.3 Pulse Damper Installation

1. Position the pulse damper, aligning it with the four mounting holes in the bottom of the cabinet. The pressure transducer should be pointed toward the rear of the cabinet.
2. From the underside of the pump cabinet, tighten the four screws to hold the pulse damper in place.
3. Connect the tubing from the pump head to the port at the rear of the pulse damper (i.e., toward the rear of the cabinet). Connect the line from the prime/purge valve to the other port, toward the front panel.
4. Connect the transducer's wire harness connector to pressure board connector P6.
5. Replace the cover on the pump.

5.6 Cleaning the Pump

1. Disconnect the column inlet tube from the column.
2. Direct the column inlet tube (the tube from the injector outlet) to a waste beaker.
3. Set the flow rate to maximum.
4. Turn the injector to the INJECT position.
5. Pump 100% isopropanol through the pump and injector for 3 minutes.
6. Pump 100% filtered, distilled water through the pump and injector for 3 minutes.

For stainless steel flow paths, proceed to Step 7; For PEEK™ flow paths, the cleaning procedure is completed.

WARNING: Use standard laboratory procedures and extreme care when handling strong acids and bases.

7. Pump a 20% nitric acid/water solution through the pump and injector for 3 minutes.
8. Flush the pump and injector with 100% filtered, distilled water for at least 3 minutes.
9. Pump 100% isopropanol through the pump and injector for 3 minutes.

The pump is now prepared for any mobile phase or short- or long-term shutdown.

5.7 Cleaning the cabinet

Cabinet may be cleaned with tap water or a mild soap solution.

5.8 Lubrication

The Prep pump has modest lubrication requirements. The bearings in the pump housing and piston carrier are permanently lubricated and require no maintenance. A small dab of a light grease such as Lubriplate 630-AA on the cam is the only recommended lubrication. Be sure not to get lubricant on the body of the piston carrier, as this can retard its movement and interfere with proper pumping.

Note: Keeping the interior of the pump free of dirt and dust will extend the pump's useful life.

5.9 Fuse Replacement

Three fuses protect the Prep pump. Two of the fuses are located in the power entry module at the rear of the cabinet and are in series with the AC input line. The other fuse is located on the motor power circuit board and is in series with the 48 Vdc supply.

Troubleshooting the fuses is straightforward. If the power cord is plugged in and the ON/OFF power entry switch is ON and the fan does not run, check the two fuses in the power entry module. To gain access to these fuses, gently pry off the cover plate with a small flat-bladed screwdriver. Replace with fuses of the correct rating: 2 A slow-blo 250 Vac.

If the front panel appears to function normally but the pump motor does not run, check the fuse located on the motor power circuit board. Replace it with a 5 A slo-blo fuse.

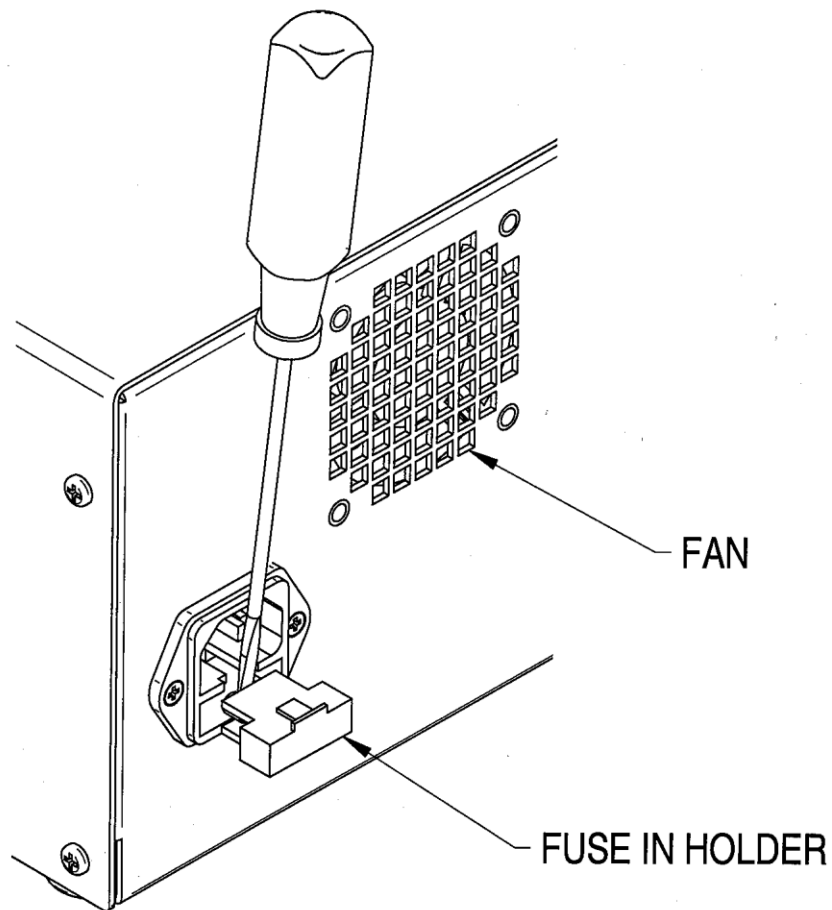

6. Quick Guide to Problem Solving

You Notice	This May Mean	Possible Cause	You Should
<ol style="list-style-type: none"> 1. Uneven pressure trace. 2. Pressure drops. 3. Pump shuts OFF. 4. No flow out the outlet check valve. 	<ol style="list-style-type: none"> 1. Bubble in check valve. 2. Leaks in system. 3. Dirty check valve. 4. Bad check valve. 	<ol style="list-style-type: none"> 1. Solvent not properly degassed. 2. Fittings are not tight. 3. Mobile phase not properly filtered. 4. Particles from worn piston seal caught in check valve. 5. Plugged inlet filter. 	<ol style="list-style-type: none"> 1. Check to be certain that mobile phase is properly degassed. 2. Check connections for leaks by tightening fittings. 3. Prime the system directly from the outlet check valve. 4. Clean or replace the check valves. See Section 5.4. 5. Clean or replace inlet filter. See Section 5.1.1.
<ol style="list-style-type: none"> 1. Uneven pressure trace. 2. Pressure drops. 3. Fluid between the pump head and the chassis. 	<ol style="list-style-type: none"> 1. Leaks in system. 2. The piston seal(s) are worn. 	<ol style="list-style-type: none"> 1. Fittings not tight. 2. Long usage time since last seal change. 3. Salt deposits on seal (especially if buffered aqueous mobile phases are used without the self-flush head.) 	<ol style="list-style-type: none"> 1. Check all connections for leaks. 2. Replace piston seal. See Sections 5.2 and 5.3. 3. Check the piston for salt deposits. Clean as necessary. See Section 5.2.4.
Pump makes a loud clanging or slapping noise (intermittent contact with cam).	Piston carrier is catching in piston guide.	<ol style="list-style-type: none"> 1. Cap nut screws on the pump head are loose. 2. Seal(s) are worn. 3. Piston guide is worn 4. Salt build-up on piston carrier from use of buffers. 5. Excess lubricant on piston carrier. 	<ol style="list-style-type: none"> 1. Check cap nut screws on pump head. Tighten if necessary. 2. Replace seals. 3. Replace piston guide and seals. See Sections 5.2 and 5.3. 4. Consider changing to a self-flushing pump head if using buffers. 5. Clean excess lubricant and dirt off piston carrier. See Section 5.7.
Blue dye in mobile phase.	Pulse damper diaphragm has burst.	Sudden pressure drop when purging system.	Replace pulse damper. See Section 5.5.
Pump runs for 50 pump strokes, and then shuts down.	Lower pressure limit is activating.	<ol style="list-style-type: none"> 1. Mobile phase is not properly filtered. 2. Particles from worn seal trapped in the system (e.g., tubing, filters, injection valve, column inlet). 	<ol style="list-style-type: none"> 1. Check to be certain the low-pressure limit is set to 0 psi. 2. Only increase the low-pressure limit after the pump attains operating pressure. 3. Contact service technician.
<ol style="list-style-type: none"> 1. Pump shuts down after run is called even with no column connected. 2. Pump runs to maximum pressure and shuts down. 	Clog in fluid system.		<ol style="list-style-type: none"> 1. Remove and clean both the inlet and bulkhead filters. See Section 5.2. 2. If the problem persists, remove tubing from system one piece at a time until you find the clogged piece. Most clogs occur outside the pump itself.
No power when pump turned ON. Fan does not run.	Blown fuses in the power entry module.	<ol style="list-style-type: none"> 1. Power surge. 2. Internal short. 	<ol style="list-style-type: none"> 1. Replace only with the appropriate fuses 2A 250Vac. 2. Contact service technician if problem persists.
Front panel appears OK but pump motor does not run.	Blown fuse on the motor power circuit board.	<ol style="list-style-type: none"> 1. Power surge. 2. Internal short. 	<ol style="list-style-type: none"> 1. Replace only with the appropriate fuse. 2. Contact service technician if problem persists.
PEEK fittings or components leak.	You cannot force PEEK parts with interference to seal by brute force tightening.	<ol style="list-style-type: none"> 1. Film of fluid between surfaces. 2. Salt crystals between surfaces. 3. Scratches in mating surfaces. 	<ol style="list-style-type: none"> 1. Clean and dry mating surfaces. 2. If scratched, replace defective part.
Self-flush heads leak flush solution.	Flush area not sealed.	<ol style="list-style-type: none"> 1. Large (Size 016) O-ring is flattened and no longer seals. 2. Head not sufficiently tightened. 3. Scratches in mating surfaces. 4. Leaky self-flush seal. 	<ol style="list-style-type: none"> 1. Replace O-ring. 2. Tighten head. 3. Replace leaky parts.

7. REPLACEMENT PARTS

PREP 36, SS

880203*	Seal Kit, Aqueous, 10/12mL
880204*	Seal Kit, Organic, 10/12mL
880401*	Check Valve Kit
880701	Repl. Outlet Filter Element (2)
880721	Repl. Inlet Filter Elements (2)
880651	Prime Purge Valve Rebuild Kit
880603	Pulse Damper Rebuild Kit
880334*	Head & S/F Kit, 10/12mL
880354*	Series II-IV Piston, 10/12mL
880412*	Self-Flush Check Valve Kit
880611	Repl. Pulse Damper
880163	PC Board Assembly (includes EPROM)
880122	Front Panel Assembly
880904	Prep Overlay

PREP 36, (PEEK™)

880203*	Seal Kit, Aqueous, 10/12mL
880204*	Seal Kit, Organic, 10/12mL
880402*	Check Valve Kit
880711	Repl. Outlet Filter Element
880721	Repl. Inlet Filter Elements (2)
880652	Prime Purge Valve Rebuild Kit
880603	Pulse Damper Rebuild Kit
880333*	Head & S/F Kit, 10/12mL
880354*	Series II-IV Piston, 10/12mL
880412*	Self-Flush Check Valve Kit
880612	Repl. Pulse Damper
880163	PC Board Assembly (includes EPROM)
880122	Front Panel Assembly
880904	Prep Overlay

* Part number for single piece, 2 are required for the Dual Piston Pumps

APPENDIX A

A.1 Rear Panel Serial Communications Port

USB and RS-232C ports are provided on the back panel. The USB interface has priority, and is automatically selected when present -- communication via the modular RS232 jack is disabled when the USB port is occupied. A computer with appropriate software can be used as a remote controlling device for pump operation via this connection. Additional drivers may be required for utilization of the USB port. The proper driver is FTDI FTD2XX and may be downloaded from the SSI LabAlliance website at the following address:

www.laballiance.com From the laballiance home page, select the Support tab, then the DownLoads tab

A.1.1 Hardware Implementation

The RS-232 REMOTE INPUT serial communications port is configured for 9600 baud, 8 data bits, 1 stop bit, and no parity. The connector is a standard RJ-11 modular telephone type jack. When looking at the connector on the rear panel of the pump, pin 1 is at the top and pin 6 is at the bottom. The pin-out configuration is:

<u>Pin</u>	<u>Function</u>
1, 6	Ground
2	DSR (Handshaking input to pump)
3	RXD (Serial data input to pump)
4	TXD (Serial data output from pump)
5	DTR (Handshaking output from pump)

Special wiring considerations: Use the following chart for interfacing the pump's serial communications port to either a 25-pin or a 9-pin COM port on an PC type computer.

<u>Pump (RJ11)</u>	<u>Signal</u>	<u>IBM (DB25)^a</u>	<u>IBM (DB9)^b</u>
1, 6	Ground	7	5
2	DSR	20	4
3	RXD	2	3
4	TXD	3	2
5	DTR	6	6

^a Jumper pins 4, 5, and 8 on DB25.
^b Jumper pins 1, 7, and 8 on DB9.

Part Description	Part Number
Modular Cable	120677
Adapter RJ-11 to DB9	120672
Adapter RJ-11 to DB-25	120671
USB Cable A-B	936031

A.1.2 Hand-Shaking

The pump uses hardware handshaking. The pump will not transmit on the TXD output if the DSR input is at a low logic level. And, the pump will not receive on the RXD input when the DTR output is at a low logic level. A low logic level is -3.0 to -15 volts and a high logic level is 3.0 to 15 volts.

A.1.3 Command Interpreter

The pump's high-level command interpreter receives and responds to command packets. The pump will not send a message except when prompted, and it will send a response to every valid command as described below. The response to an invalid command is "Er".

Each command is characterized by a unique two-letter command code, and only one command can be issued per line. Case is not important; that is, the command codes "PR" "Pr" "pR" and "pr" are all equivalent. Response strings sent by the pump are terminated by the "/" character.

If the pump's response is "Er/", send a "#" to clear any characters which may be remaining in the command buffer. The pump will automatically clear all characters in the command buffer after one second elapses from the time at which the last character of an incomplete command was sent.

The command packets are as follows:

Command	Response	Comments
RU	OK/	Sets the pump to the RUN state.
ST	OK/	Sets the pump to the STOP state.
FLxxx	OK/	Sets the flow rate to x.xx or xx.x mL/min where the range is fixed for the pump head size, i.e., for 0.01 to 24.00 mL/min xxx = 001 to 999, for 0.1 to 100.0 mL/min xxx = 001 to 999.
FOxxxx	OK/	Sets the flow rate to xx.xx or xxx.x mL/min where the range is fixed for the pump head size, i.e., for 0.01 to 24.00 mL/min xxxx = 0001 to 1000, for 0.1 to 100.0 mL/min xxxx = 0001 to 1000.

PR	OK,x/ (x, xx, xxx, or xxxx)	Reads the pump's current pressure, where: x, xx, xxx, or xxxx = Current pressure in PSI
CC	OK,x,y.yy/ (x, xx, xxx, or xxxx) (y.yy, yy.yy, or yy.y)	Reads the pump's current pressure and flowrate, where: x, xx, xxx, or xxxx = Current pressure in PSI y.yy, yy.yy, or yy.y = Flow rate in mL/min The format is y.yy and yy.yy for a standard pump head or yy.y for a macro pump head.
CS	OK,x.xx,y,z,PSI,w,v,u/ (x.xx, xx.xx, or xx.x) (y, yy, yyy, or yyyy) (z, zz, zzz, or zzzz)	Reads the current pump setup, where: x.xx, xx.xx, or xx.x = Flow rate in mL/min y, yy, yyy, or yyyy = Upper pressure limit z, zz, zzz, or zzzz = Lower pressure limit PSI = Units (PSI, ATM, MPA, BAR, or KGC) w = Pump head size (0 = standard, 1 = macro) v = Run status (0 = stopped, 1 = running) u = Pressure Board present = 0; otherwise 1
ID	OK,vx.xx SR3P firmware/	Identifies the pump type and EPROM revision x.xx
UPxxxx	OK/	Sets the upper pressure limit in PSI. The maximum value for xxxx is 5000 for the plastic head or 8000 for the steel head; the minimum value is the lower limit plus 100. The value must be expressed as four digits, i.e., for 900 PSI xxxx = 0900.
LPxxxx	OK/	Sets the lower pressure limit in PSI. The maximum value for xxxx is the current upper pressure limit setting minus 100; the minimum value is 0. The value must be expressed as four digits, i.e., for 100 PSI xxxx = 0100.
SF	OK/	Puts the pump in fault mode. Turns on the FAULT LED and stops the pump immediately.
RF	OK,x,y,z/	Reads the fault status, where: x = Motor stall fault (0 = no, 1 = yes) y = Upper pressure limit fault (0 = no, 1 = yes) z = Lower pressure limit fault (0 = no, 1 = yes)
KD	OK/	Disables the keypad. (Default status at power-up is enabled.)
KE	OK/	Enables the keypad.
PCxx	OK/	Sets the pressure compensation value, where xx = the operating pressure (in PSI divided by 100), i.e., for 0 PSI xx = 00, for 5000 PSI xx = 50.
RC	OK,x/ (x or xx)	Reads the pressure compensation value in hundreds of PSI, i.e., for 0 PSI x = 0, for 5000 PSI xx = 50.
HTx	OK/	Sets the pump head type, where: x = 1 for a stainless steel 10/12mL/min pump head x = 2 for a plastic 10/12mL/min pump head x = 3 for a stainless steel 40/50mL/min pump head x = 4 for a plastic 40/50mL/min pump head The pump is stopped; and, the pressure compensation and pressure limits are initialized, when the head type is changed.

RH	OK,x/	Reads the pump head type, where: x = 1 for a stainless steel 10/12 mL/min pump head x = 2 for a plastic 10/12mL/min pump head x = 3 for a stainless steel 40/50 mL/min pump head x = 4 for a plastic 40/50 mL/min pump head
PI	OK,a.aa,b,c,d,e,f,g,h,i,j,k,l,m,n,o,p,q/ (a.aa, aa.aa, or aa.a) (c or cc)	Reads the current pump setup, where: a.aa, aa.aa, or aa.a = Flow rate in mL/min b = Run status (0 = stopped, 1 = running) c or cc = Pressure compensation d = Pump head type (see RH command) e = Pressure Board present = 0; otherwise 1 f = External control mode (0 = frequency, 1 = voltage) g = 1 if pump started and frequency controlled, else 0 h = 1 if pump started and voltage controlled, else 0 i = Upper pressure limit fault (0 = no, 1 = yes) j = Lower pressure limit fault (0 = no, 1 = yes) k = Priming (0 = no, 1 = yes) l = Keypad lockout (0 = no, 1 = yes) m = PUMP-RUN input (0 = inactive, 1 = active) n = PUMP-STOP input (0 = inactive, 1 = active) o = ENABLE IN input(0 = inactive, 1 =active) p = Always 0 q = Motor stall fault (0 = no, 1 = yes)
RE	OK/	Resets the pump configuration to its default power-up state.
#	(no response)	Clears all characters from the command buffer.

If the pump's response is "Er", send a "#" to clear any characters which may be remaining in the command buffer. The pump will automatically clear all characters in the command buffer after one second elapses from the time at which the last character of an incomplete command was sent.

A.2 Rear Panel 4-Pin and 10-Pin Terminal Board Connectors

A 4-pin terminal board connector and a 10-pin terminal board connector are provided on the back panel. Any device capable of providing the proper run/stop logic level, flow rate control frequency, or flow rate control voltage can be used as a remote controlling device for pump operation via this connection. The terminal board connectors can be removed for ease of connecting wires, if desired, by pulling firmly rearward and should be reinserted firmly afterward.

A.2.1 Pressure Fault and Motor Stall Fault Output

The pump's output is on the 4-pin terminal board connector. The pinout configuration is:

<u>Pin</u>	<u>Function</u>
4	EVENT 1
3	EVENT 2
2	EVENT 3
1	GROUND

This output is produced internally by a reed relay which has SPDT contacts with a 0.25 amp maximum, 50 VDC maximum, 0.2 ohm rating. The 4-pin connector allows wires to be connected to the EVENT 1 (Pole), EVENT 2 (NC), and EVENT 3 (NO) terminals. When the pump stops due to the sensed pressure exceeding the set pressure limits or if a motor stall fault occurs, the connection between the EVENT 1 terminal and the EVENT 2 and EVENT 3 terminals is affected. EVENT 2 is Normally Closed (connected to EVENT 1) until a fault occurs and then opens. EVENT 3 is Normally Open (not connected to EVENT 1) until a fault occurs and then closes.

A.2.1.1 Upper and Lower Pressure Limit Range

The pressure sensing transducer provides accurate, wide range pressure monitoring. Because of the sensitivity of the transducer, the zero reading may shift up to 0.1% of the full pressure scale over years of operational use. The user should also be aware that the resistance to flow of the fluid being pumped through the tubing and fittings may cause the pressure to vary with the flow rate and the viscosity of the mobile phase employed.

If absolute accuracy is needed for the pressure safety limits:

1. Disconnect the column from pumping system and operate the pump with the mobile phase and flow rate to be used in the analysis. Observe the resulting pressure displayed on the pump readout. The column will cause a pressure reading that adds to this basic reading due to system flow resistance.
2. Set the upper limit shut-off to a pressure equal to the basic reading *plus* the safe operating pressure for the column to be used. For example, if the basic pressure reading (without the column) is 7 PSI and the safe limit for the column is 25 PSI, set the maximum pressure limit to 32 PSI or less.
3. If the mobile phase or flow rate is changed, reset the pressure limit as appropriate.

4. Note that a lower pressure limit is available to prevent continued operation in the event of a leak. For proper operation, this must be set to a pressure higher than the basic pressure or it may not sense the reduced pressure.

A.2.2 General Information on Inputs

The pump's inputs are on the 10-pin terminal board connector. The pinout configuration is:

<u>Pin</u>	<u>Function</u>
10	VOLTAGE COM
9	VOLTAGE IN
8	FREQ IN
7	ENABLE IN
6	PUMP-RUN
5	PUMP-STOP
4	No connection
3	No connection
2	No connection
1	COM

A.2.3 General Information on Run, Stop, and Enable Inputs

The PUMP-RUN, PUMP-STOP, and ENABLE IN inputs operate from an internal 5 VDC source, and each one draws approximately 0.008 amps when connected to COM. To activate either the PUMP-RUN, PUMP-STOP, or ENABLE IN input connect it to COM. Any device capable of switching 0.008 amps can be connected between the PUMP-RUN, PUMP-STOP, or ENABLE IN input and COM, such as: a switch contact, a relay contact, an open collector output, an open drain output, or any output with a high logic level output of 3.8 to 6.0 volts and a low logic level output of 0.0 to 0.5 volts. A switch contact or a relay contact is preferred since this type of connection will provide isolation between the pump and the controlling device. The COM terminal is internally connected to the pump's chassis ground and should be connected to the controlling device's ground or zero volt terminal when the controlling device has an open collector output, an open drain output, or any output with logic level output.

A.2.4 Run and Stop Inputs

The pump's motor can be commanded to run or stop from the back panel inputs when the pump's flow rate is controlled from the front panel or when the pump's flow rate is controlled by the voltage or frequency input. There two modes of

operation for the run and stop inputs which are described below:

Dual Signal Pulse: In this mode of operation both the PUMP-RUN and PUMP-STOP inputs are normally at a high logic level. To start the pump, pulse the PUMP-RUN input to a low logic level for a minimum of 500 mS. To stop the pump, pulse the PUMP-STOP input to a low logic level for a minimum of 500 mS.

Single Signal Level: To enable this mode of operation the PUMP-STOP input must be permanently connected to COM with a jumper wire. To start the pump, put a low logic level on the PUMP-RUN input. To stop the pump, put a high logic level on the PUMP-RUN input.

A.2.5 Enable Input

When activated (ENABLE IN is at a low logic level), the ENABLE IN input disables flow rate control on the front panel and enables flow rate control on the back panel.

A.2.6 General Information on Voltage and Frequency Inputs

Special programming and circuitry allows this pump to be operated remotely with the flow rate controlled by voltage or frequency inputs. To select the remote mode of operation:

- a.) With the pump plugged in and the rear panel power switch OFF, press in and hold the "DOWN ARROW" button while turning the power switch ON.
- b.) Release the "DOWN ARROW" button and either a U (closest approximation to V for voltage) or an F (for frequency) will be displayed.
- c.) Select the desired remote operating mode by pressing the "DOWN ARROW" button to toggle between the voltage and frequency mode.
- d.) Press the "RUN/STOP" button to place the pump in normal operating mode.
- e.) To enable the currently selected remote mode (voltage or frequency), connect the rear panel ENABLE IN connection to the COM connection.
- f.) When in the remote mode (ENABLE IN at a low logic level) all front panel buttons remain active except the flow setting increase/decrease capability.

A.2.7 Voltage Input

The remote voltage flow control is implemented by connecting a negative input to the rear panel VOLTAGE COM connection and a positive input to the VOLTAGE IN connection. A 0-10 VDC input corresponds to a 0 to 12 mL/min for Prep 24 pumps and 0 to 100 mL/min for Prep 100 pumps. Any device capable of sourcing at least 0.0005 amps will work. The voltage control mode must also be selected and enabled as described in section “A.2.5” above. The voltage source, which drives the VOLTAGE IN and VOLTAGE COM connections, must be isolated from the safety ground to prevent a ground loop current. If the pump’s displayed flow rate jumps up and down erratically, suspect a ground loop problem. Flow rate instabilities may exist for input voltages below 10mV.

A.2.8 Frequency Input

The remote frequency flow control is implemented by connecting a negative input to the COM connection and +5 VDC square wave input to the FREQ IN connection. Any device capable of sinking and sourcing at least 0.008 amps will work. A 0 to 10,000 Hertz input frequency will correspond to a 0 to 24 mL/min flow rate for Prep 24 pumps and 0 to 100mL/min for Prep 100 pumps. The frequency control mode must also be selected and enabled as described in section “A.2.5” above.

Scientific Systems

WARRANTY STATEMENT

Scientific Systems, Inc. (SSI) warrants that instruments or equipment manufactured by it for a period thirty-six (36) months from date of shipment to customer, against defects in materials and workmanship under normal installation, use and maintenance. Expendable items and physical damage caused by improper handling or damage caused by spillage or exposure to any corrosive environment are excluded from this warranty. The warranty shall be void for Polyetheretherketone (PEEK) components exposed to concentrated Nitric or Sulfuric acids which attack PEEK, or methylene chloride, DMSO or THF which adversely affect UHMWPE seals and PEEK tubing. Any defects covered by this warranty shall be corrected by replacing or repairing, at SSI's option, parts determined by SSI to be defective.

Spare or replacement parts and accessories shall be warranted for a period of 12 months from date of installation at customer against defects in materials and workmanship under normal installation, use and maintenance. Defective Product will be accepted for return only if customer returns them to SSI within thirty (30) days from the time of discovery of the alleged defect, and prior to return, obtains a Return Goods Authorization (RGA) number from SSI, and provides SSI with the serial number of each instrument to be returned. Freight costs for the return of defective Product is the responsibility of SSI. SSI shall specify the freight carrier for returns.

The warranty shall not apply to any Product that has been repaired or altered except by SSI or those specifically authorized by SSI, to the extent that such repair or alteration caused the failure, or to Product that has been subjected to misuse, negligence, accident, excessive wear, or other causes not arising out of a defect in material or workmanship.

The warranty shall not apply to wear items, specifically:

Check Valves	Piston and Wash Seals
Pistons	Pulse-Damper Diaphragms
Inlet Lines	Filter Elements

The following is the exclusive procedure by which to make claims under this warranty. Customer shall obtain SSI's oral or written authorization to return the product and receive a Return Goods Authorization (RGA) number. The Product must be returned with the RGA number plainly visible on the outside of the shipping container to SSI. It must be securely packed in a rigid container with ample cushioning material, preferably the original packaging. All claimed defects must be specified in writing, including the RGA number, with the written claim accompanying the Product. Product shall be shipped to SSI at customer's expense. SSI shall bear the expense of return shipment.

If it appears to SSI that any Product has been subjected to misuse, negligence, accident or excessive wear, or is beyond the warranty period, customer shall be notified promptly. SSI shall notify customer of its finding and provide an estimate to repair such Product at the then current rates for parts and service. SSI shall either repair the product per customer's authorization or shall return such Product not repaired to customer at customer's expense. SSI may invoice customer for the freight costs of any Product shipped back to customer by SSI which is not covered under the warranty.

Limitations of Warranty. THE FOREGOING WARRANTIES AND LIMITATIONS ARE CUSTOMER'S EXCLUSIVE REMEDIES AND ARE IN LIEU OF ALL OTHER WARRANTIES, EXPRESS OR IMPLIED, INCLUDING WITHOUT LIMITATION ANY WARRANTY OF MERCHANTABILITY OR FITNESS FOR A PARTICULAR PURPOSE.
